

KINTEK

TOOLHOLDERS FOR CNC LATHES (BMT, BOLT-ON, VDI DIN69880)
PORTAUTENSILI PER TORNI CNC (BMT, BOLT-ON, VDI DIN69880)

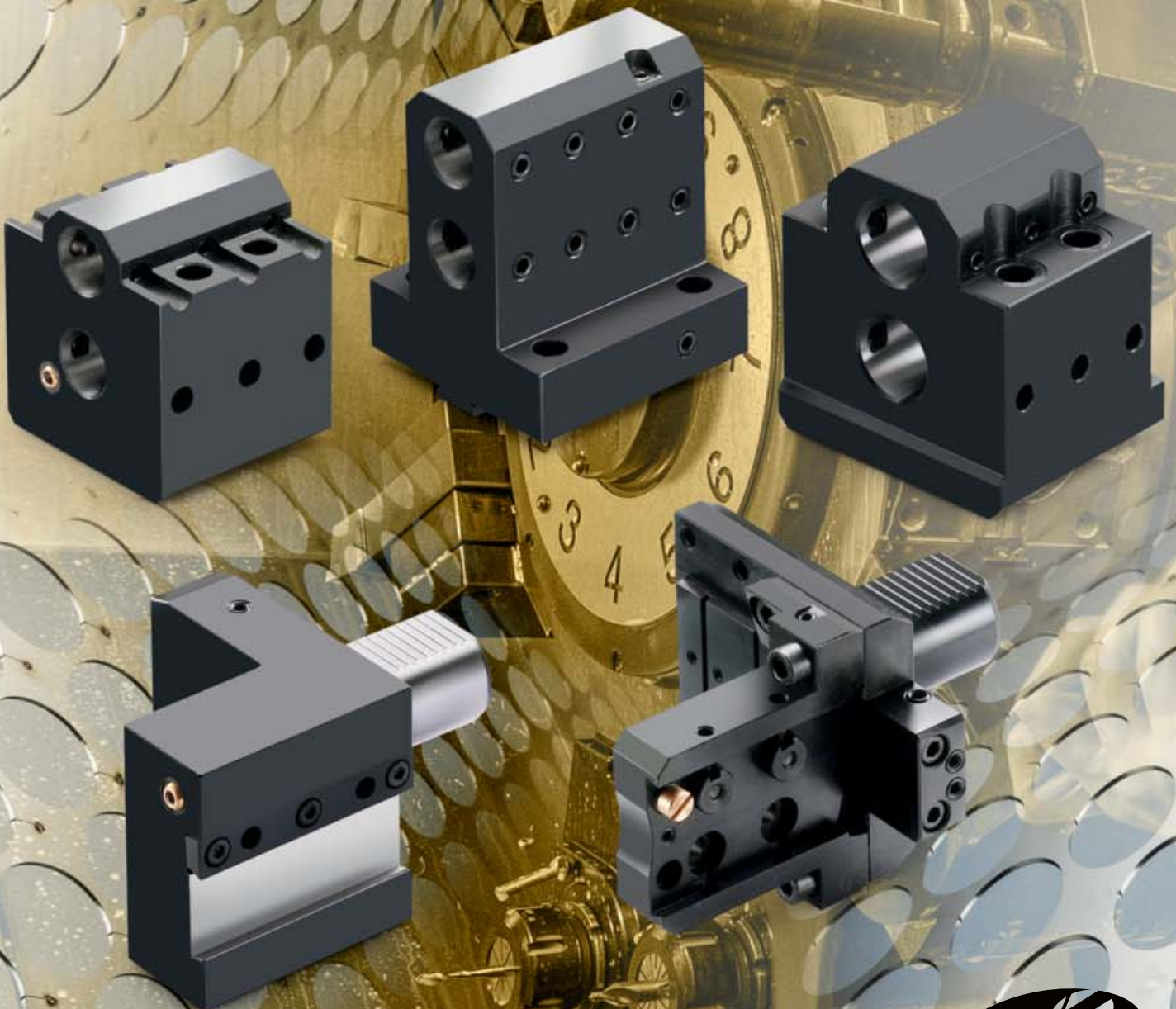

**TOOLHOLDERS FOR CNC LATHES
(BMT, BOLT-ON, VDI DIN69880)**



CNC-DREHEMASCHINEN
(BMT, BOLT-ON, VDI DIN69880)



РЕЗЦЕДЕРЖАТЕЛИ ДЛЯ
ТОКАРНЫХ СТАНКОВ С ЧПУ
(BMT, BOLT-ON, VDI DIN69880)



PORTE-OUTILS POUR TOURS CNC
(BMT, BOLT-ON, VDI DIN69880)



PORTAUTENSILI PER TORNII CNC
(BMT, BOLT-ON, VDI DIN69880)



数控车床刀柄
BMT, BOLT-ON, VDI DIN69880



SONDER-WERKZEUGHALTER PORTEOUTILS SPECIAUX
SPECIAL TOOLHOLDERS PORTAUTENSILI SPECIALI
СПЕЦИАЛЬНЫЕ РЕЗЦЕДЕРЖАТЕЛИ 专用刀柄

BIGLIA TOOLHOLDERS*PORTAUTENSILI BIGLIA*

Pag. 465

DMG MORI TOOLHOLDERS*PORTAUTENSILI DMG MORI*

Pag. 466-482

OKUMA TOOLHOLDERS*PORTAUTENSILI OKUMA*

Pag. 483-491

NAKAMURA TOME TOOLHOLDERS*PORTAUTENSILI NAKAMURA*

Pag. 492-495

DOOSAN PUMA TOOLHOLDERS - BMT 45 /55/65/75*PORTAUTENSILI DEWOO PUMA*

Pag. 496-502

MAZAK TOOLHOLDERS*PORTAUTENSILI MAZAK*

Pag. 503-505

WFL TOOLHOLDERS*PORTAUTENSILI WFL*

Pag. 506

GOODWAY TOOLHOLDERS*PORTAUTENSILI GOODWAY*

Pag. 507

BIGLIA

**B301/445/470/501(Y-S)/510/545/550/565/650/658
1200/446/465/745/765-B750/1250 16 ST.**

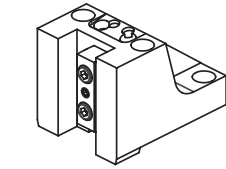

128-41524
128-41525 (25x25 mm)

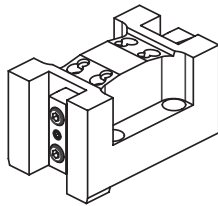

128-41527

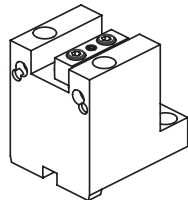

128-31515

Face and O.D.
cutting holder

Face and O.D.
cutting holder

Face and O.D.
cutting holder

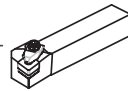

Qualified tool
20x20 mm

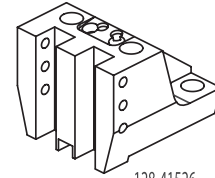

128-41526

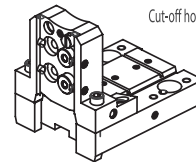

Cut-off holder

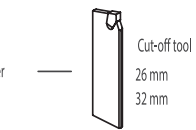

Cut-off tool
26 mm
32 mm

128-11566 (26 mm)
128-11567 (32 mm)

ACCESSORIES

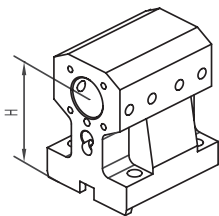

128-21538 H=80
128-21540 H=100

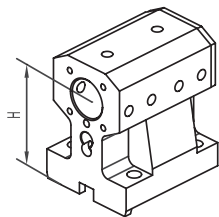

128-21539 H=80
128-21541 H=100

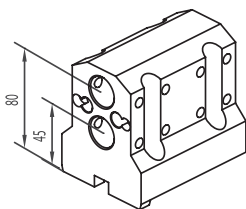

128-21542

Toolholder
for boring bar

Ø32 mm

Combi toolholder
for boring bar
and insert drill

Ø32 mm

Toolholder
for boring bar

2xØ25 mm

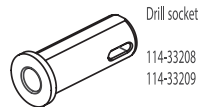

Drill socket
114-33208 <MT1>
114-33209 <MT2>

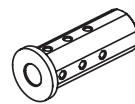

Boring bar sleeve
115-63260 (Ø8 mm)
115-63261 (Ø10 mm)
115-63211 (Ø12 mm)
115-63212 (Ø16 mm)
115-63213 (Ø20 mm)

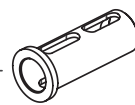

Boring bar sleeve
115-63214 (Ø25 mm)

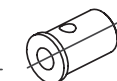

Throw-away drill socket
165-63325 (Ø16 mm)
165-63326 (Ø20 mm)
165-63327 (Ø25 mm)

CONNECTION

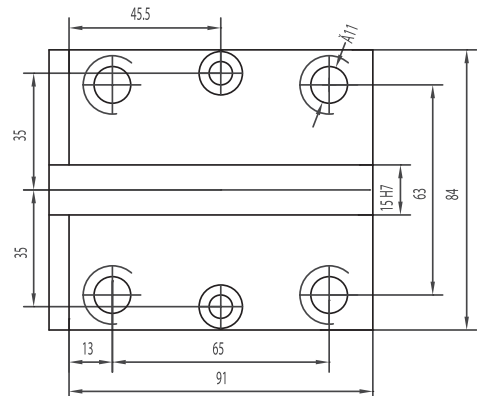

DMG MORI (VDI30)

CTX 210/310/410 V3/V1 - CTX 320/420 V3
 CTX Alpha 300/500 V3
 CTX Beta 500/800/1250 V3 (option)
 CTV 160

AXIAL TURRET

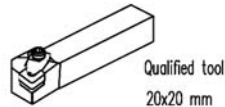
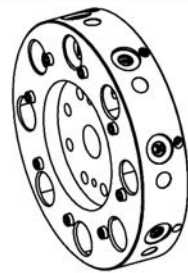
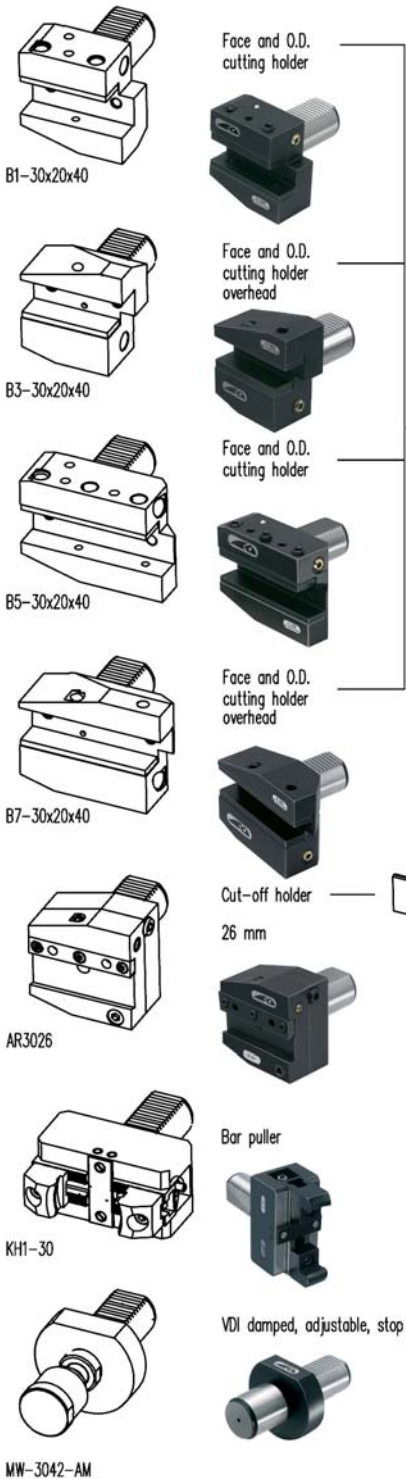

ACCESSORIES



Boring bar sleeve $\varnothing 25$ mm
 115-62574 ($\varnothing 8$ mm)
 115-62575 ($\varnothing 10$ mm)
 115-62576 ($\varnothing 12$ mm)
 115-62577 ($\varnothing 16$ mm)
 115-62578 ($\varnothing 20$ mm)

Boring bar sleeve $\varnothing 32$ mm
 165-63223 ($\varnothing 8$ mm)
 165-63224 ($\varnothing 10$ mm)
 165-63225 ($\varnothing 12$ mm)
 165-63226 ($\varnothing 16$ mm)
 165-63227 ($\varnothing 20$ mm)
 165-63228 ($\varnothing 25$ mm)

Boring bar sleeve $\varnothing 40$ mm
 165-64075 ($\varnothing 8$ mm)
 165-64076 ($\varnothing 10$ mm)
 165-64077 ($\varnothing 12$ mm)
 165-64078 ($\varnothing 16$ mm)
 165-64079 ($\varnothing 20$ mm)
 165-64080 ($\varnothing 25$ mm)
 165-64081 ($\varnothing 32$ mm)

Toolholder for insert drill

E1-30x08WN ($\varnothing 8$ mm)
 E1-30x10WN ($\varnothing 10$ mm)
 E1-30x12WN ($\varnothing 12$ mm)
 E1-30x16 ($\varnothing 16$ mm)
 E1-30x20 ($\varnothing 20$ mm)
 E1-30x25 ($\varnothing 25$ mm)
 E1-30x32 ($\varnothing 32$ mm)
 E1-30x40 ($\varnothing 40$ mm)

Toolholder for boring bar

E2-30x6 ($\varnothing 6$ mm)
 E2-30x8 ($\varnothing 8$ mm)
 E2-30x10 ($\varnothing 10$ mm)
 E2-30x12 ($\varnothing 12$ mm)
 E2-30x16 ($\varnothing 16$ mm)
 E2-30x20 ($\varnothing 20$ mm)
 E2-30x25 ($\varnothing 25$ mm)
 E2-30x32 ($\varnothing 32$ mm)
 E2-30x40 ($\varnothing 40$ mm)

Double holder for boring bar

E7-30x25 ($\varnothing 25$ mm)

Toolholder with cylindrical shank

137-00041 ($\varnothing 40$ mm/HSK50A+C)

Collet chuck

E4-30x16 (ER16)
 E4-30x20 (ER20)
 E4-30x25 (ER25)
 E4-30x32 (ER32)
 E4-30x40 (ER40)

Drilling chuck

KS2-30-13 ($\varnothing 1$ - $\varnothing 13$ mm)
 KS2-30-16 ($\varnothing 3$ - $\varnothing 16$ mm)

DMG MORI (VDI30)

CTX 310/410 V4/V6 - CTX 320 V4/V6
 CTX 420 V4/V6 (option) - CTX Alpha 300 V4
 CTX Alpha 500 V 4/V6
 CTX Beta 500/800/1250 V4/V6 (option)
 TWIN 42/65/102
 SPRINT 65/50

RADIAL TURRET

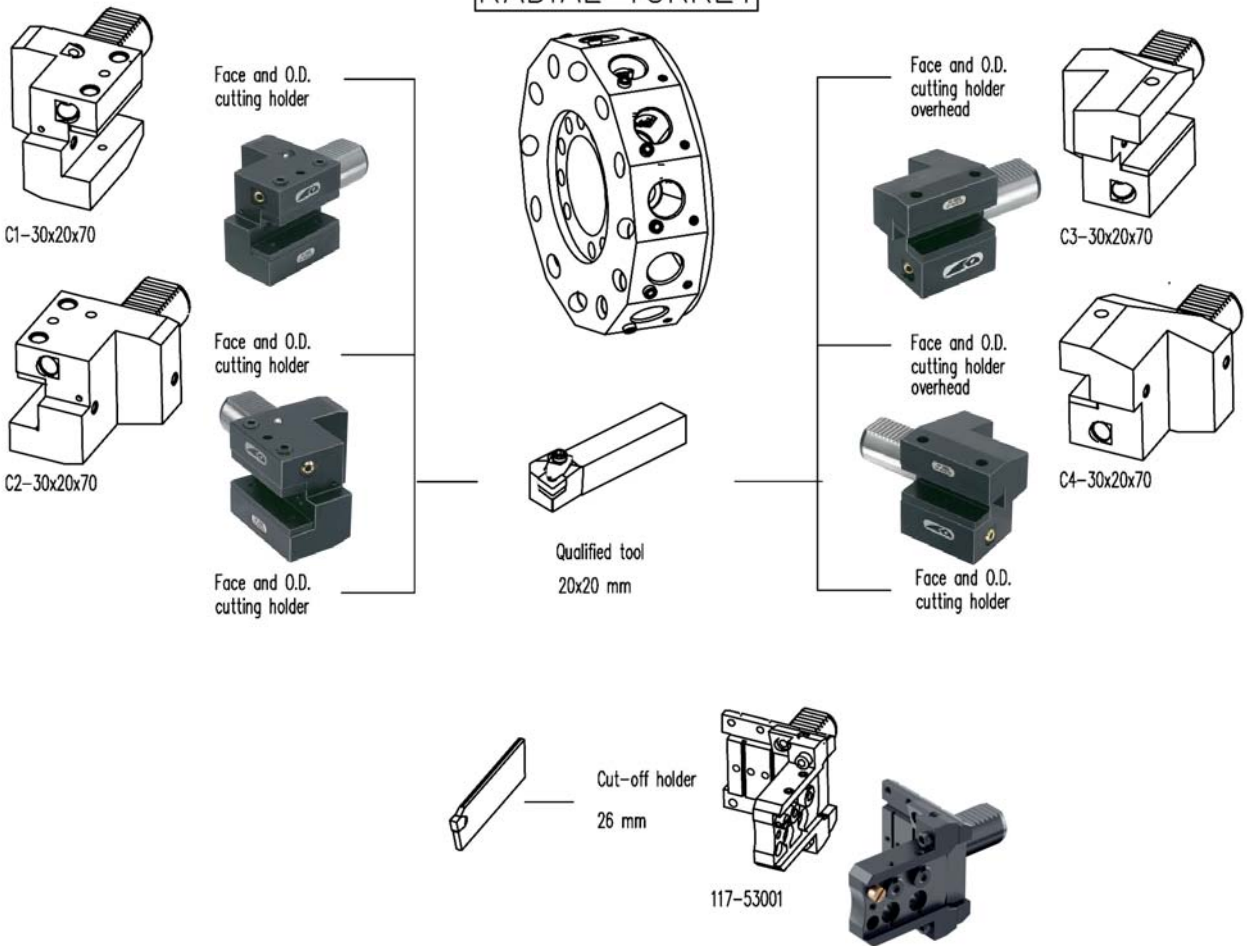

DMG MORI (VDI30)

CTX310/410 V4/V6 - CTX 320 V4/V6
CTX420 V4/V6 (option) - CTX Alpha 300 V4
CTX Alpha 500 V4/V6
CTX Beta 500/800/1250 V4/V6 (option)
TWIN 42/65/102
SPRINT 65/50

RADIAL TURRET

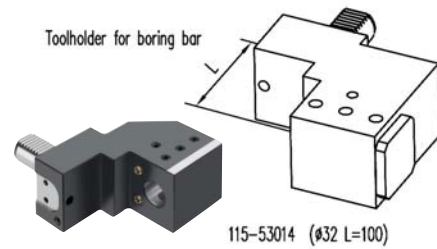
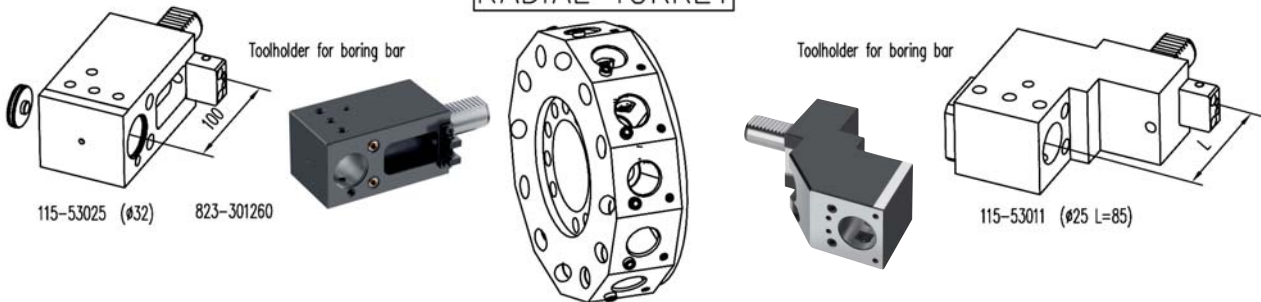

ACCESSORIES

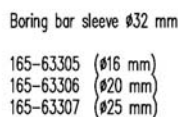
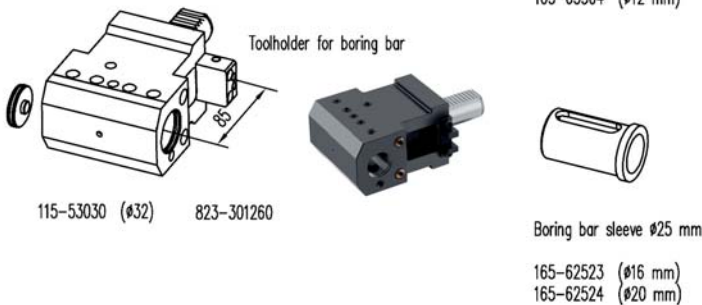
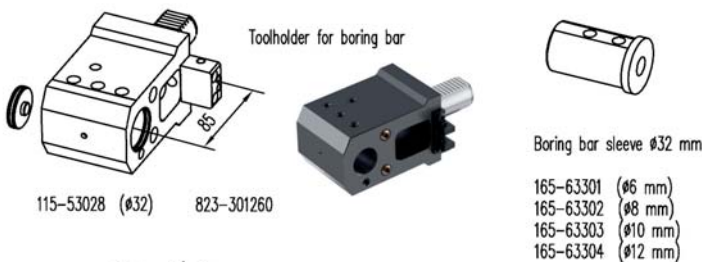

DMG MORI (VDI40)

- CTX410 V3 (option)
- CTX510 V3/V4
- CTX420 V3 (option)
- CTX520 V3/V4
- CTX Beta 500/800/1250 V3/V4
- CTX Gamma 1250/2000 V3/V4 (option)

AXIAL TURRET



Face and O.D. cutting holder



Face and O.D. cutting holder overhead

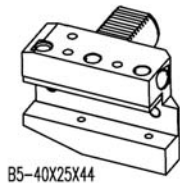

Face and O.D. cutting holder



Face and O.D. cutting holder overhead

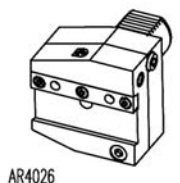

Cut-off holder
26 mm/32 mm

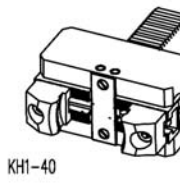

Bar puller



VDI damped, adjustable, stop bar

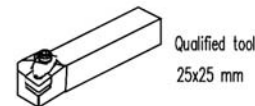
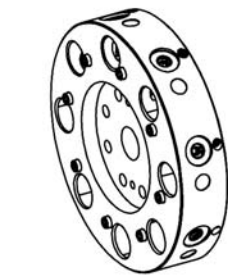

ACCESSORIES

Boring bar sleeve $\varnothing 25$ mm

- 115-62579 ($\varnothing 8$ mm)
- 115-62580 ($\varnothing 10$ mm)
- 115-62581 ($\varnothing 12$ mm)
- 115-62582 ($\varnothing 16$ mm)
- 115-62583 ($\varnothing 20$ mm)

Boring bar sleeve $\varnothing 32$ mm

- 165-63223 ($\varnothing 8$ mm)
- 165-63224 ($\varnothing 10$ mm)
- 165-63225 ($\varnothing 12$ mm)
- 165-63226 ($\varnothing 16$ mm)
- 165-63227 ($\varnothing 20$ mm)
- 165-63228 ($\varnothing 25$ mm)

Boring bar sleeve $\varnothing 40$ mm

- 165-64082 ($\varnothing 8$ mm)
- 165-64083 ($\varnothing 10$ mm)
- 165-64084 ($\varnothing 12$ mm)
- 165-64085 ($\varnothing 16$ mm)
- 165-64086 ($\varnothing 20$ mm)
- 165-64087 ($\varnothing 25$ mm)
- 165-64088 ($\varnothing 32$ mm)

Toolholder for insert drill

- E1-40x06WN ($\varnothing 6$ mm)
- E1-40x08WN ($\varnothing 8$ mm)
- E1-40x10WN ($\varnothing 10$ mm)
- E1-40x12WN ($\varnothing 12$ mm)
- E1-40x16 ($\varnothing 16$ mm)
- E1-40x20 ($\varnothing 20$ mm)
- E1-40x25 ($\varnothing 25$ mm)
- E1-40x32 ($\varnothing 32$ mm)
- E1-40x40 ($\varnothing 40$ mm)
- E1-40x50 ($\varnothing 50$ mm)

Toolholder for boring bar

- E2-40x6 ($\varnothing 6$ mm)
- E2-40x8 ($\varnothing 8$ mm)
- E2-40x10 ($\varnothing 10$ mm)
- E2-40x12 ($\varnothing 12$ mm)
- E2-40x16 ($\varnothing 16$ mm)
- E2-40x20 ($\varnothing 20$ mm)
- E2-40x25 ($\varnothing 25$ mm)
- E2-40x32 ($\varnothing 32$ mm)
- E2-40x40 ($\varnothing 40$ mm)
- E2-40x50 ($\varnothing 50$ mm)

Double holder for boring bar

- E7-40x32 ($\varnothing 32$ mm)

Collet chuck

- E4-40x20 (ER20)
- E4-40x25 (ER25)
- E4-40x32 (ER32)
- E4-40x40 (ER40)

Drilling chuck

- KS2-40-13 ($\varnothing 1$ - $\varnothing 13$ mm)
- KS2-40-16 ($\varnothing 3$ - $\varnothing 16$ mm)

DMG MORI
(VDI40)

CTX410 V4/V6 (option) - CTX420 V4/V6
 CTXBeta 500/800/1250 V6
 TWIN42/65/102 RG2 - GMX250/300/400/500
 SPRINT65 (option)

RADIAL TURRET

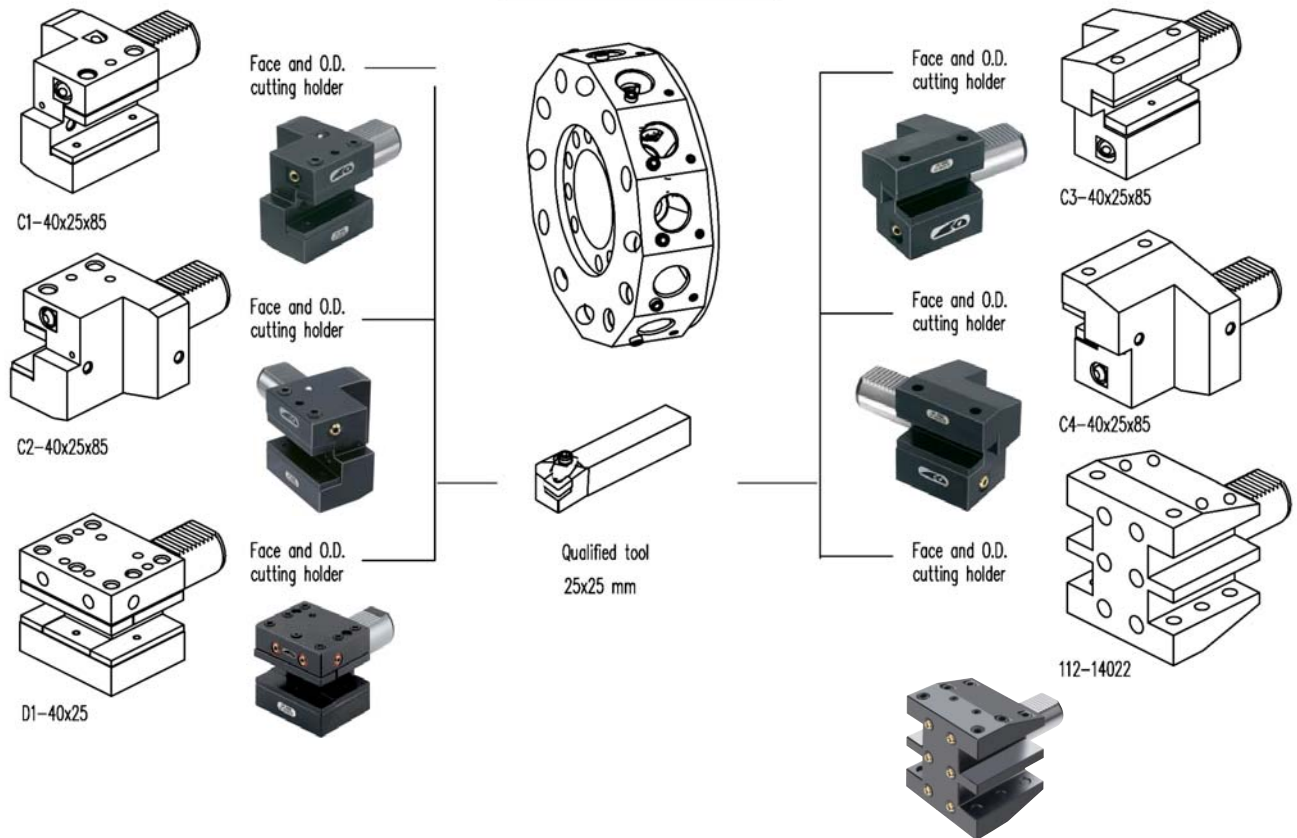

DMG MORI (VDI40)

CTX410 V4/V6 (option) - CTX420 V4/V6
 CTXBeta 500/800/1250 V4/V6
 TWIN42/65/102 RG2 - GMX250/300/400/500
 SPRINT65 (option)

RADIAL TURRET

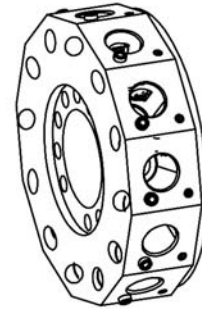
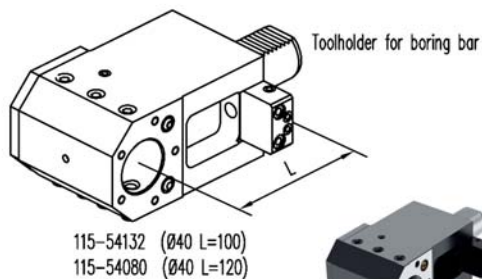
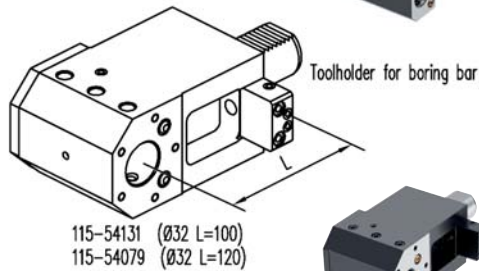
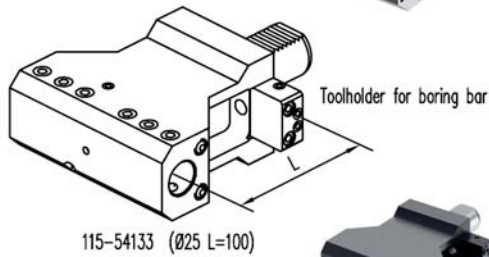
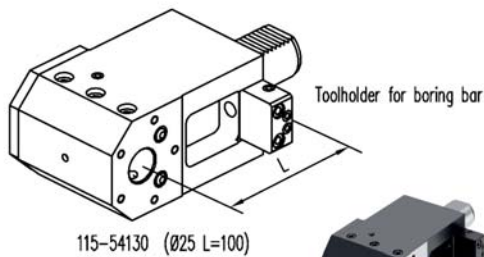

ACCESSORIES



- Boring bar sleeve (Ø25)
- 115-62579 (Ø8)
 - 115-62580 (Ø10)
 - 115-62581 (Ø12)
 - 115-62582 (Ø16)
 - 115-62583 (Ø20)



- Boring bar sleeve (Ø32)
- 165-63223 (Ø8)
 - 165-63224 (Ø10)
 - 165-63225 (Ø12)
 - 165-63226 (Ø16)
 - 165-63227 (Ø20)
 - 165-63228 (Ø25)



- Boring bar sleeve (Ø40)
- 165-64082 (Ø8)
 - 165-64083 (Ø10)
 - 165-64084 (Ø12)
 - 165-64085 (Ø16)
 - 165-64086 (Ø20)
 - 165-64087 (Ø25)
 - 165-64088 (Ø32)

Double toolholder for boring bar

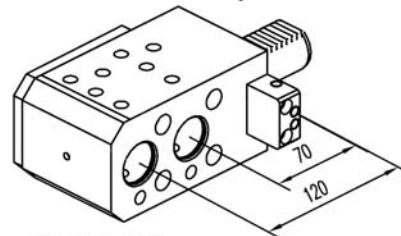

DMG MORI (VDI50)

CTX620 V3/V4/V1 CTX Gamma 1250/2000 V3/V4 CTV400 CTX Beta 2000

AXIAL TURRET

Face and O.D. cutting holder

B1-50x32x55

Face and O.D. cutting holder overhead

B3-50x32x55

Face and O.D. cutting holder

B5-50x32x55

Face and O.D. cutting holder overhead

B7-50x32x55

Cut-off holder

26 mm/32 mm

AR5026
AR5032

Bar puller

KH1-50

VDI damped, adjustable, stop bar

MW-5042-AM

Qualified tool

32x32 mm

E2-115

Boring bar sleeve #25 mm

115-62584 (Ø8 mm)
115-62585 (Ø10 mm)
115-62586 (Ø12 mm)
115-62587 (Ø16 mm)
115-62588 (Ø20 mm)

Boring bar sleeve #32 mm

165-63229 (Ø8 mm)
165-63230 (Ø10 mm)
165-63231 (Ø12 mm)
165-63232 (Ø16 mm)
165-63233 (Ø20 mm)
165-63234 (Ø25 mm)

Boring bar sleeve #40 mm

165-64082 (Ø8 mm)
165-64083 (Ø10 mm)
165-64084 (Ø12 mm)
165-64085 (Ø16 mm)
165-64086 (Ø20 mm)
165-64087 (Ø25 mm)
165-64088 (Ø32 mm)

Toolholder for insert drill

E1-50x16 (Ø16 mm)
E1-50x20 (Ø20 mm)
E1-50x25 (Ø25 mm)
E1-50x32 (Ø32 mm)
E1-50x40 (Ø40 mm)
E1-50x50 (Ø50 mm)

Toolholder for boring bar

E2-50x12 (Ø12 mm)
E2-50x16 (Ø16 mm)
E2-50x20 (Ø20 mm)
E2-50x25 (Ø25 mm)
E2-50x32 (Ø32 mm)
E2-50x40 (Ø40 mm)
E2-50x50 (Ø50 mm)

Double holder for boring bar

E7-50x32 (Ø32 mm L=50 mm)
E7-50x50 (Ø50 mm L=68 mm)

Collet chuck

E4-50x25 (ER25)
E4-50x32 (ER32)
E4-50x40 (ER40)

Drilling chuck

KS2-50-13 (Ø1-Ø13 mm)
KS2-50-16 (Ø3-Ø16 mm)

DMG MORI (HSK63T) GMX400 - GMX300 - GMX250

ATC Turret (HSK63T)

ICTM STANDARD

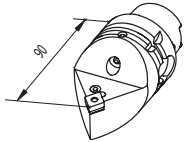

H63APCMNR12-90

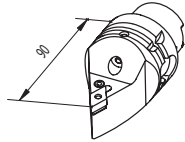

H63APDNNR15-90

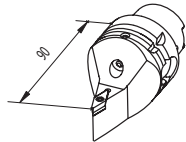

H63ASVVCN16-90

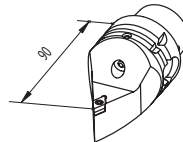

H63ASDNCN11-90

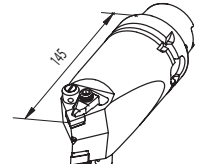

H63ADCM12DDM15-L145

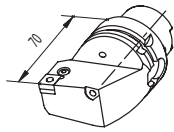

H63APCLNL/R12

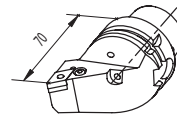

H63APDJNL/R15

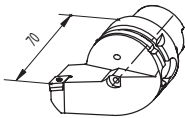

H63ASDJCL/R11

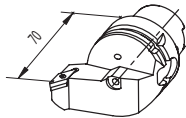

H63ASVJBL/R16

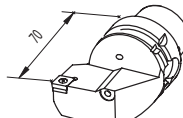

H63ASCLCL/R12

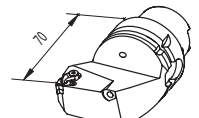

H63ATHEL/R16

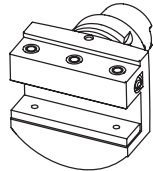

141-11408 32/25

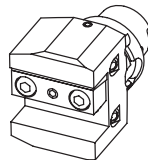

141-11406 25x25 mm

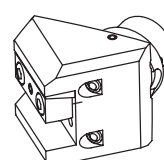

141-11405 25x25 mm

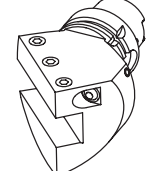

141-11407 (left) 25x25 mm
141-21401 (right)

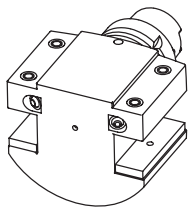

142-11405 32/25
142-11406 32/25

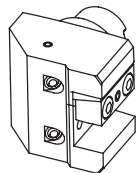

142-11402 25x25 mm

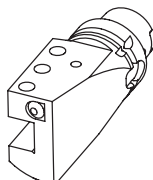

142-21401 (left) 25x25 mm
142-11403 (right)

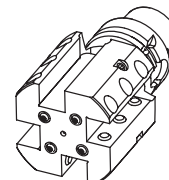

142-21404 20x20 mm (right)
142-21403 20x20 mm (left)

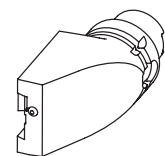

147-51405 (26mm, left)
147-51406 (26mm, right)
147-51407 (32mm, left)
147-51408 (32mm, right)

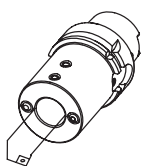

145-21404 (Ø12)
145-21406 (Ø16)
145-21408 (Ø20)
145-21409 (Ø25)
145-21410 (Ø32)
145-21411 (Ø40)

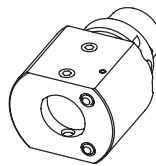

145-21412 Ø40 mm



165-64124 (Ø10 mm)
165-64125 (Ø12 mm)
165-64126 (Ø16 mm)
165-64127 (Ø20 mm)



165-64128 (Ø25 mm)
165-64129 (Ø32 mm)

DMG MORI (BMT40)

CTX310ECO-BMT / NZ1500 / NZ2000 / NTX1000-2000

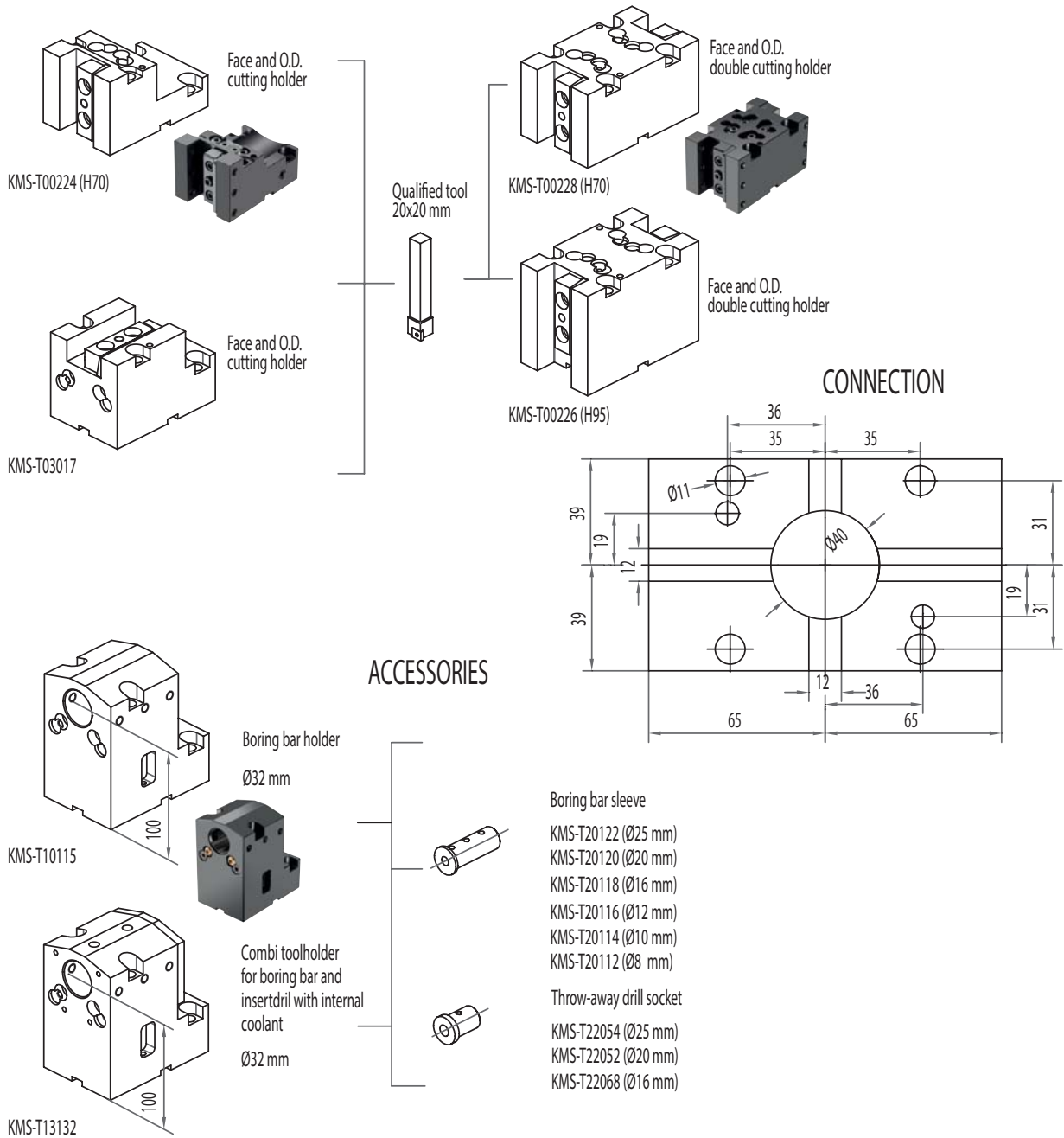

DMG MORI (BMT60)

NLX1500 - NLX2000
 NLX2500 - NLX3000
 NL2000 (S)MC - 2500 (S)MC
 NL3000MC (12 STATIONS)

CONNECTION

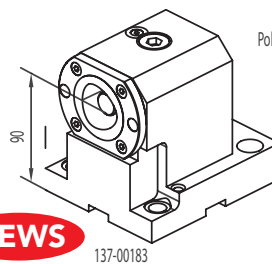
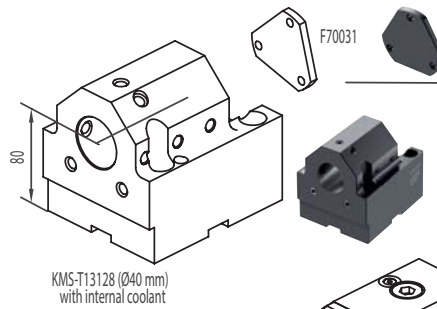
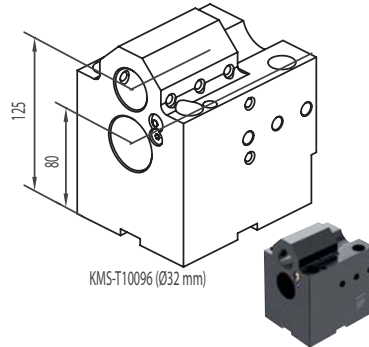
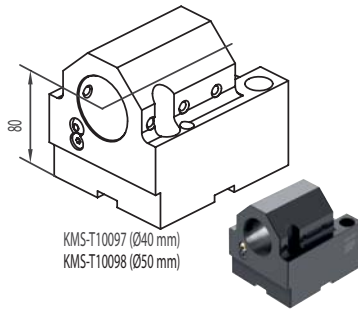
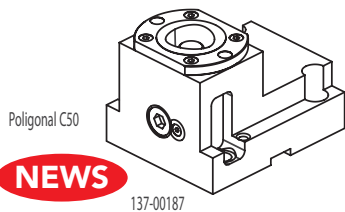
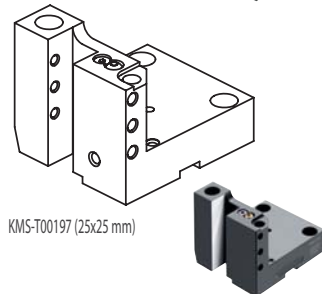
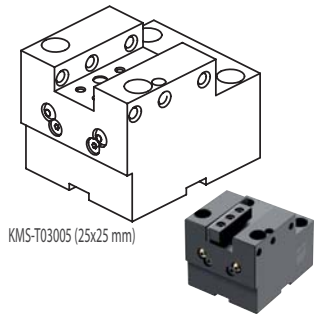
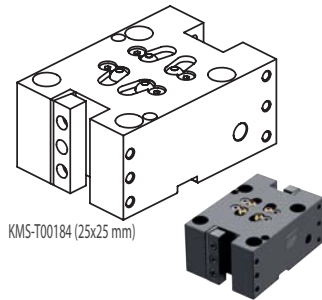
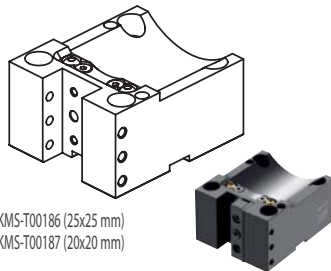
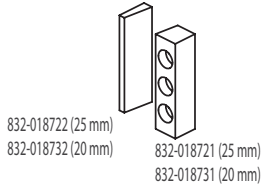
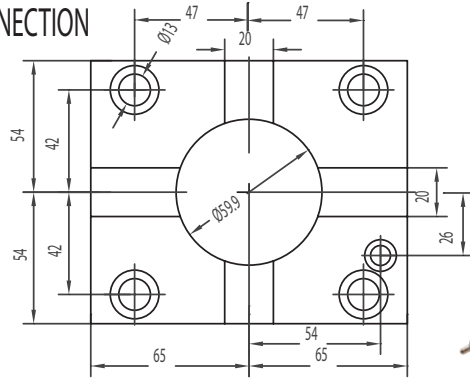

ACCESSORIES

- KMS-T20098-A (Ø32 mm)
- KMS-T20096-A (Ø25 mm)
- KMS-T20094-A (Ø20 mm)
- KMS-T20092-A (Ø16 mm)
- KMS-T20090-A (Ø12 mm)
- KMS-T20088-A (Ø10 mm)
- KMS-T20086-A (Ø8 mm)

- KMS-T20196-A (Ø20 mm)
- KMS-T20194-A (Ø16 mm)
- KMS-T20110-A (Ø12 mm)
- KMS-T20108-A (Ø10 mm)
- KMS-T20106-A (Ø8 mm)

- KMS-T22042-A (MT3)
- KMS-T22044-A (MT4)
- KMS-T22046-A (MT2)
- KMS-T22066-A (MT1)

- KMS-T20122-A (Ø25 mm)
- KMS-T20120-A (Ø20 mm)
- KMS-T20118-A (Ø16 mm)
- KMS-T20116-A (Ø12 mm)
- KMS-T20114-A (Ø10 mm)
- KMS-T20112-A (Ø8 mm)

- KMS-T20100-A (Ø32 mm)
- KMS-T20102-A (Ø25 mm)
- KMS-T20104-A (Ø20 mm)
- KMS-T20190-A (Ø16 mm)

Poligonal C50

NEWS

DMG MORI CMZ

SL203MC - SL253MC - ZL200MC
ZL250SMC - SL204SMC - SL300MC
TL20 - TL25 - TC30 - TC35

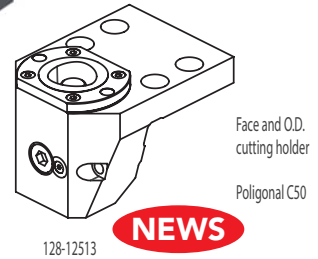
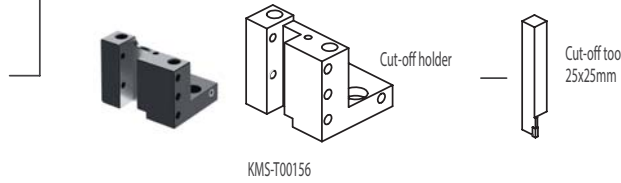
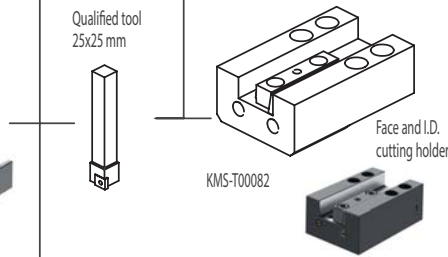
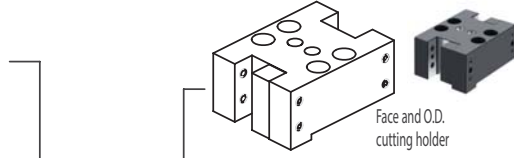
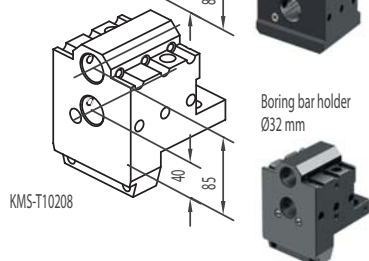
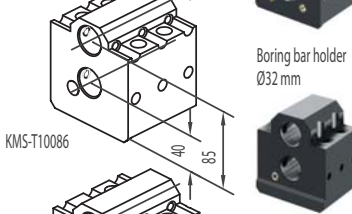
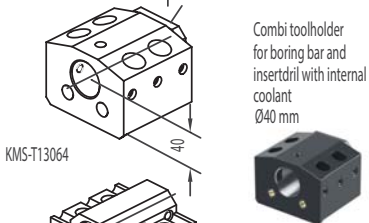
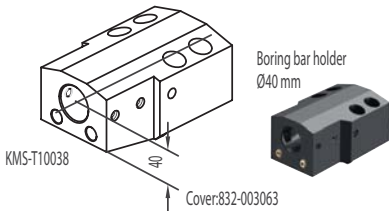
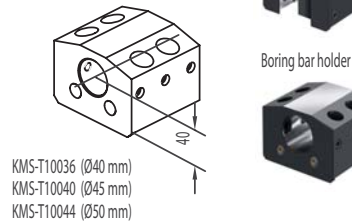
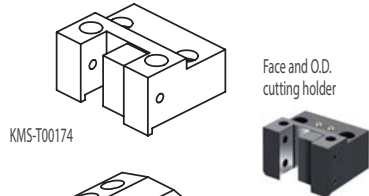
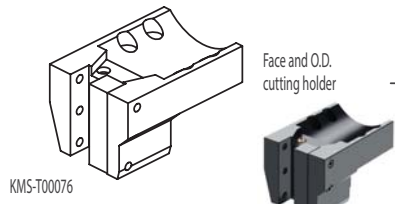
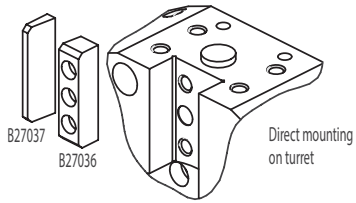

NEWS

ACCESSORIES

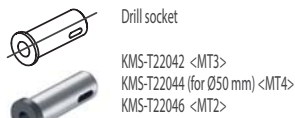

CONNECTION

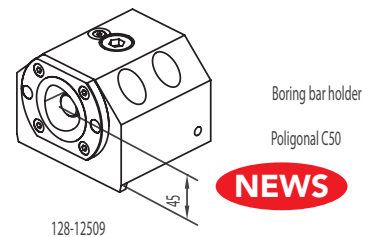
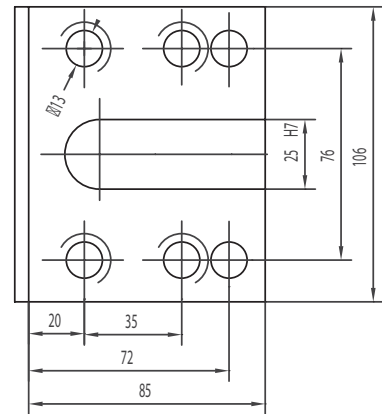

NEWS

DMG MORI CTX Gamma 1250TC / 2000TC

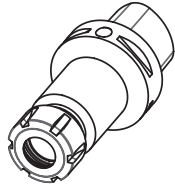

C63H60ER16 C63H100ER16
C63H60ER20 C63H100ER20
C63H60ER25 C63H100ER25
C63H60ER32 C63H100ER32
C63H70ER40 C63H130ER40



C63H55WE06 C63H65WE16
C63H55WE08 C63H65WE20
C63H60WE10 C63H80WE25
C63H60WE12 C63H90WE32
C63H60WE14



C63H40D16 C63H100D27
C63H63D16 C63H25D32
C63H25D22 C63H100D32
C63H100D22 C63H40D40
C63H25D27 C63H100D40

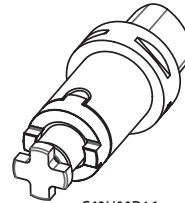

C63H90D16
C63H90D22
C63H90D27
C63H90D32
C63H90D40

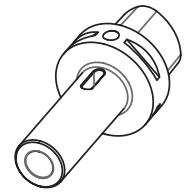

C63H110CM2P
C63H130CM3P
C63H150CM4P

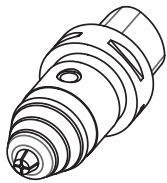

C63H112R1-13
C63H112R3-16

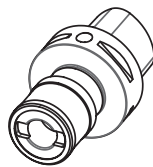

C63GR1
C63GR2

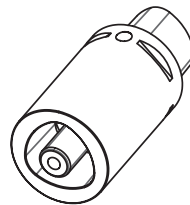

C63H100C63
C63H140C63

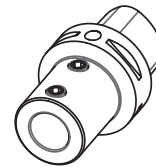

C63H60D08PNT C63H70D20PNT
C63H60D10PNT C63H72D25PNT
C63H60D12PNT C63H75D32PNT
C63H70D16PNT C63H75D40PNT

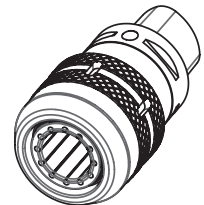

C63H80C20
C63H100C32

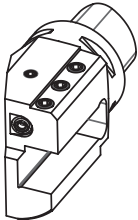

C63-AD2020R/L
C63-AD2525R/L
C63-AD3232R/L

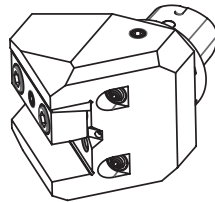

C63-ARD2525-45

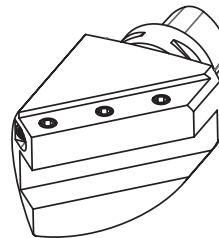

C63AR20R/L
C63AR25R/L

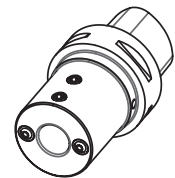

C63H80D16E2
C63H80D20E2
C63H88D25E2
C63H95D32E2
C63H105D40E2

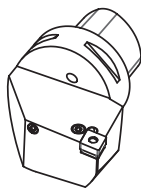

C63-PCLNR/L12
C63-PCLNR/R16



C63-PDJNR/L15



C63-25PCLNR/L12
C63-32PCLNR/L12



C63-SCLCR/L09
C63-SCLCR/R12



C63-SDJCR/L11

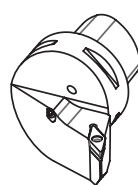

C63-SVHBR/L16
C63-SVHCR/L16

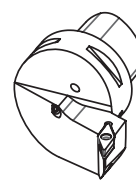

C63-SVJBR/L16
C63-SVJCR/L16

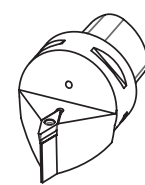

C63-SVVCN16-190

DMG MORI SL150 - SL153 - ZL150 - CL150 - SL154

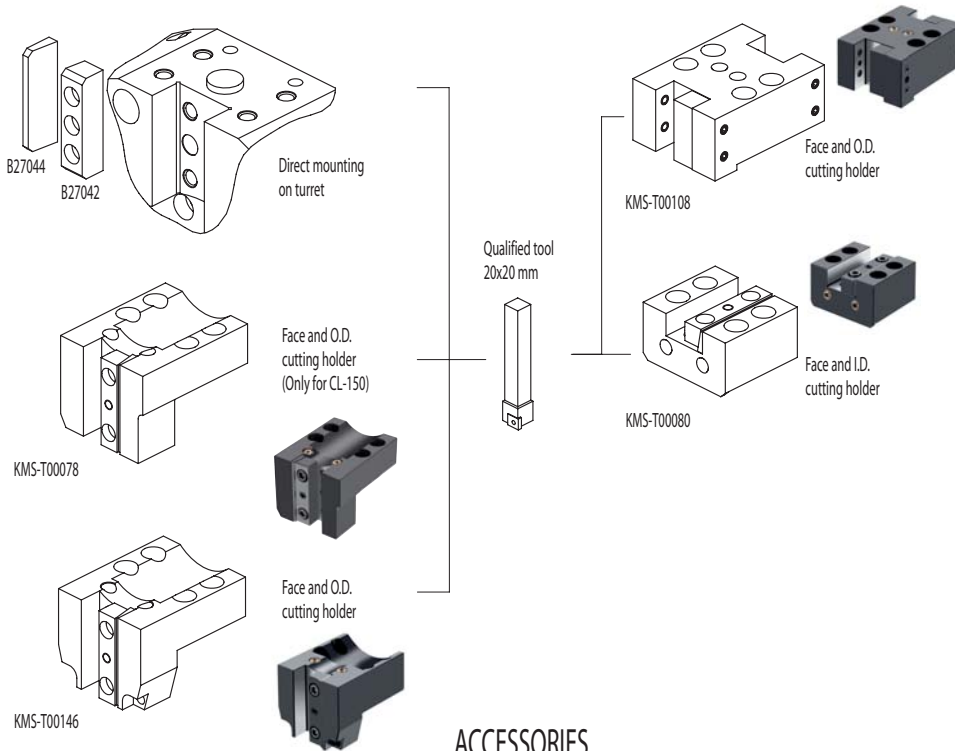

ACCESSORIES

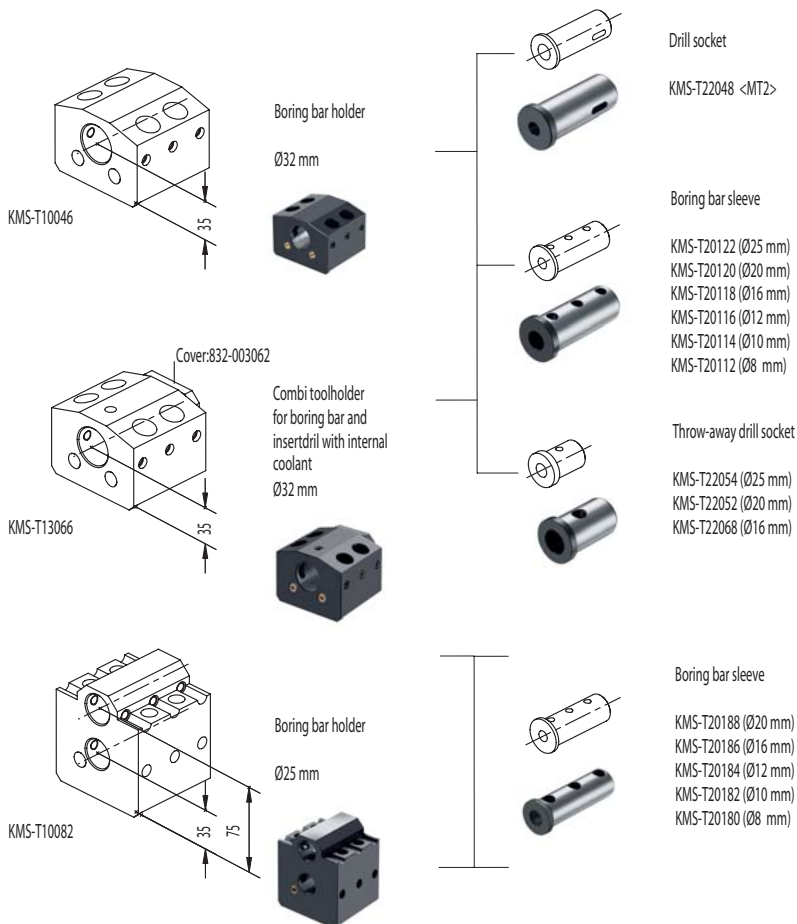

CONNECTION

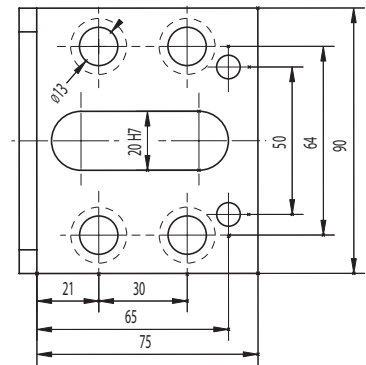

DMG MORI CMZ SL153MC - ZL150MC - SL154MC TL15

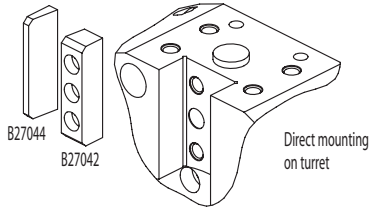

Direct mounting on turret

Qualified tool 20x20 mm

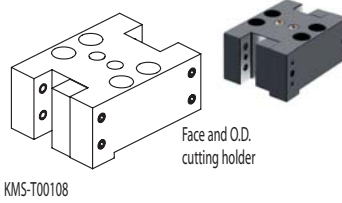

Face and O.D. cutting holder

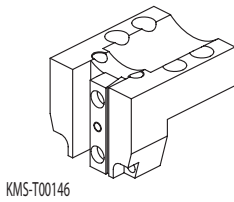

Face and O.D. cutting holder

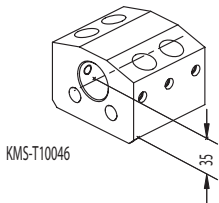

Boring bar holder

Ø32 mm

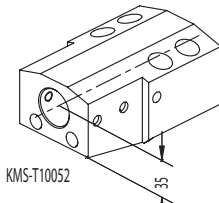

Boring bar holder

Ø32 mm

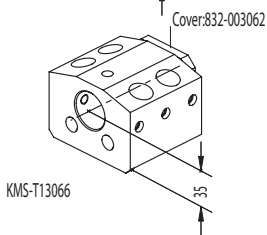

Combitool holder for boring bar and insertdrill with internal coolant

Ø32 mm

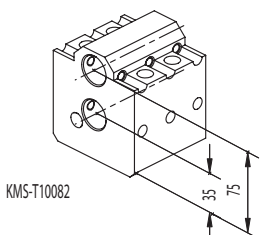

Boring bar holder

Ø25 mm



ACCESSORIES

Drill socket

- KMS-T22048 <MT2>
- KMS-T22050 <MT1>

Boring bar sleeve

- KMS-T20122 (Ø25 mm)
- KMS-T20120 (Ø20 mm)
- KMS-T20118 (Ø16 mm)
- KMS-T20116 (Ø12 mm)
- KMS-T20114 (Ø10 mm)
- KMS-T20112 (Ø8 mm)

Throw-away drill socket

- KMS-T22054 (Ø25 mm)
- KMS-T22052 (Ø20 mm)
- KMS-T22068 (Ø16 mm)

Boring bar sleeve

- KMS-T20188 (Ø20 mm)
- KMS-T20186 (Ø16 mm)
- KMS-T20184 (Ø12 mm)
- KMS-T20182 (Ø10 mm)
- KMS-T20180 (Ø8 mm)

CONNECTION

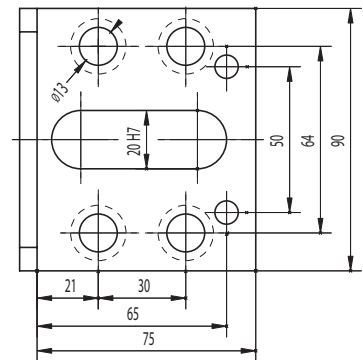

DMG MORI

**SL200 - SL203 - SL250 - SL253 - ZL200 - ZL250
(CL200) - SL204 - DURATURN 2030
DURATURN 2050 - DURATURN 2550**

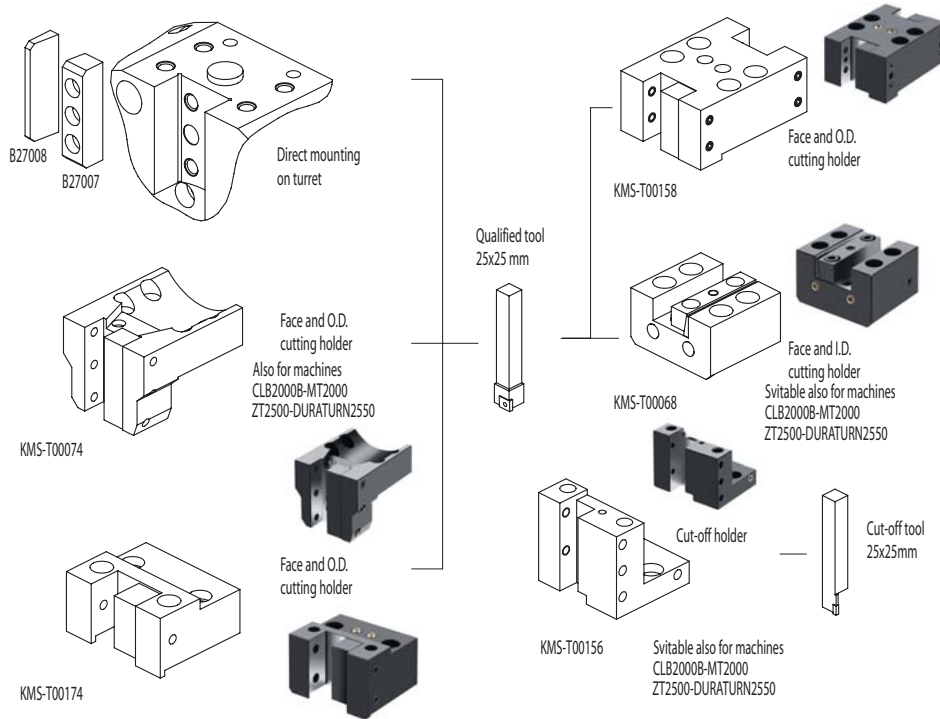

ACCESSORIES

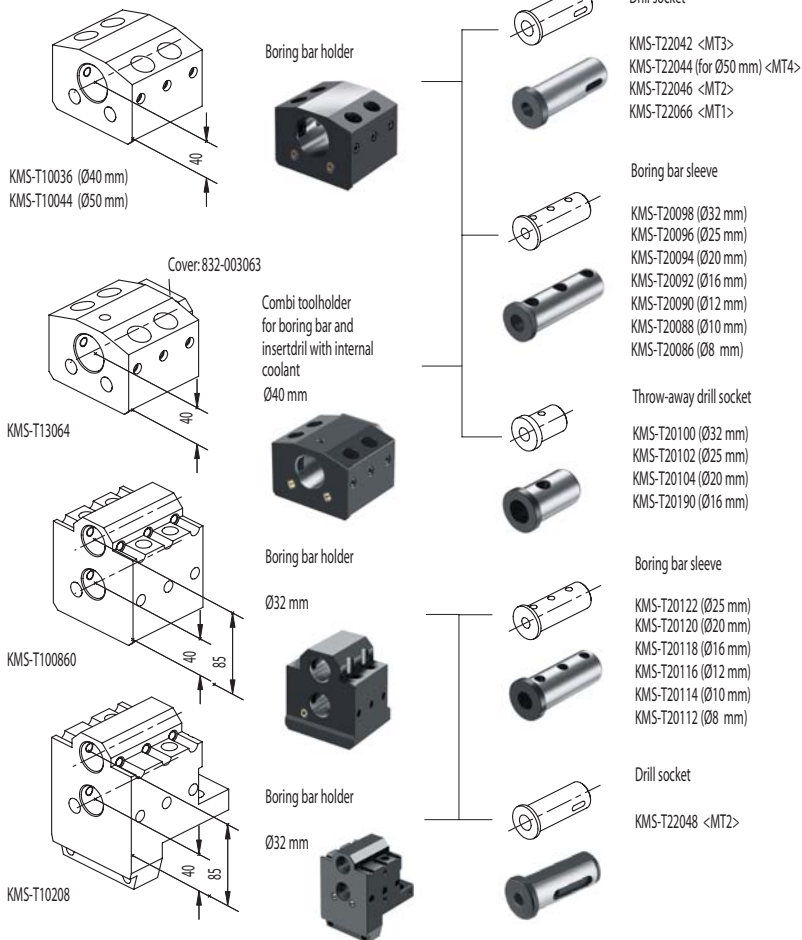

CONNECTION

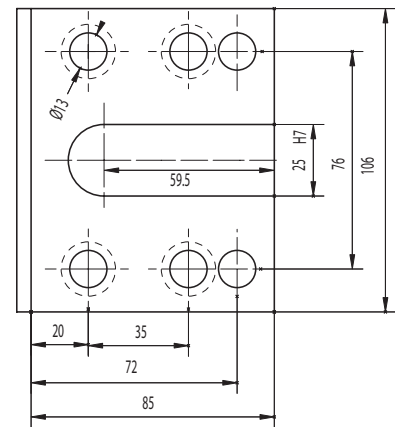

DMG MORI CXT620

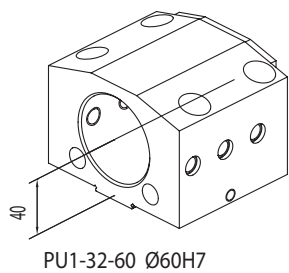
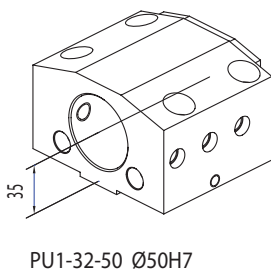
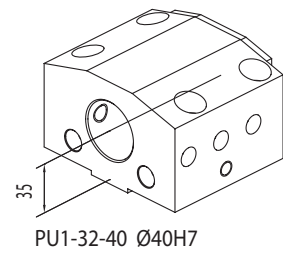
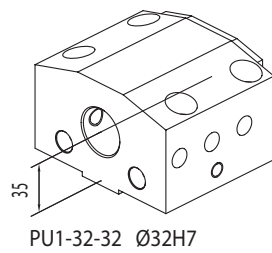
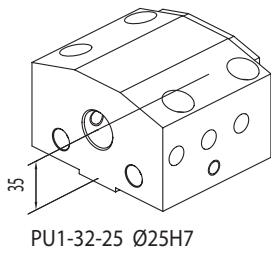
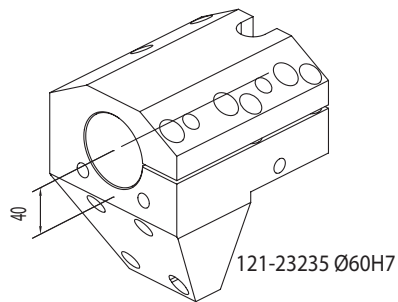
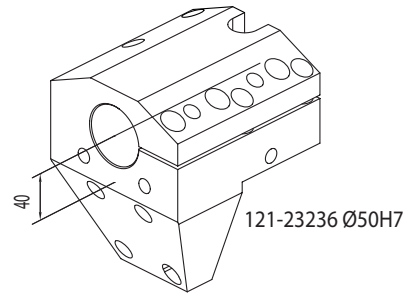
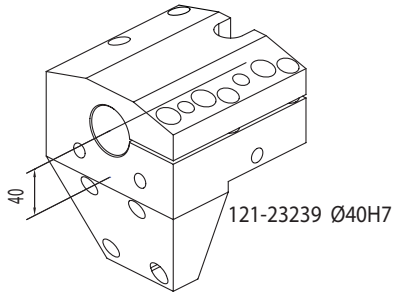

DMG MORI CTX510

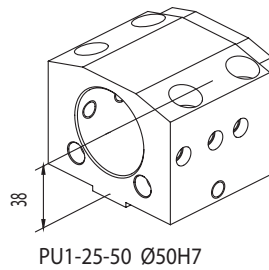
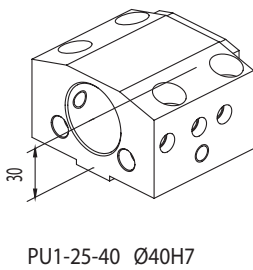
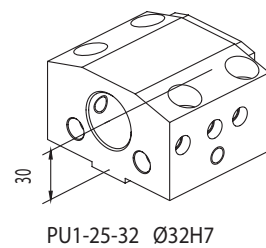
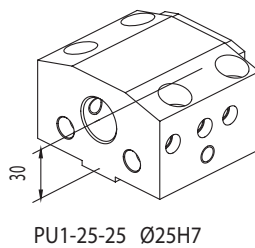
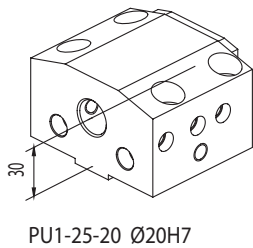
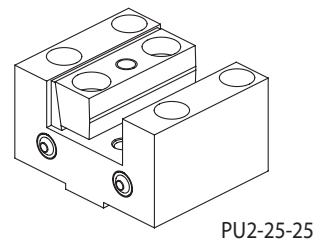
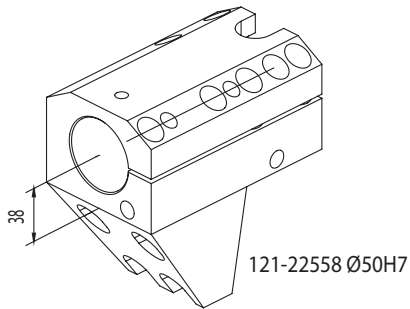
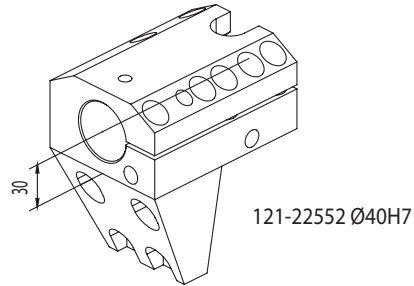

OKUMA
(VDI30)

**LT10M - LT200M
LB10**

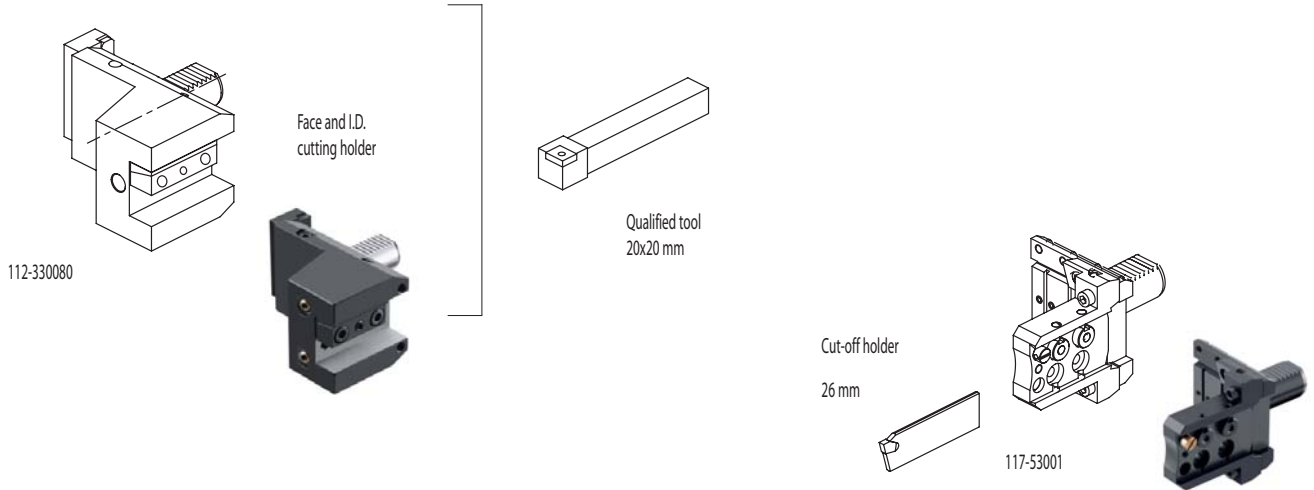

ACCESSORIES

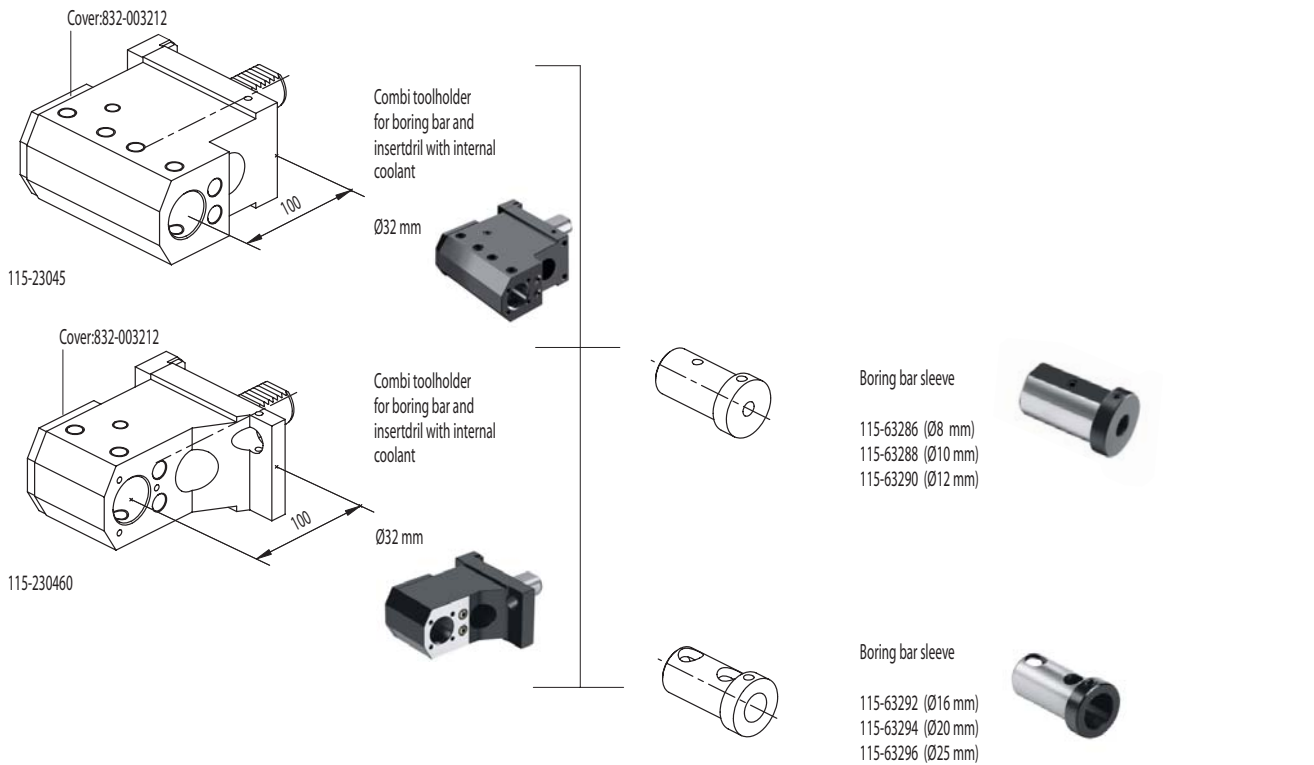

OKUMA (VDI40)

LT15M - LT300M - MT250
LB300 - LB300M - LV300

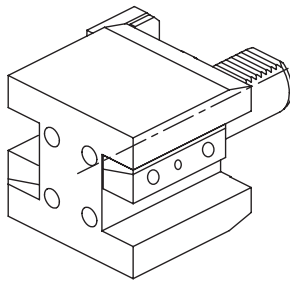

112-14009

Face and O.D.
cutting holder



ACCESSORIES

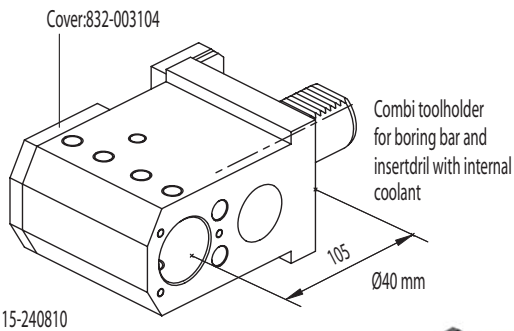

115-240810

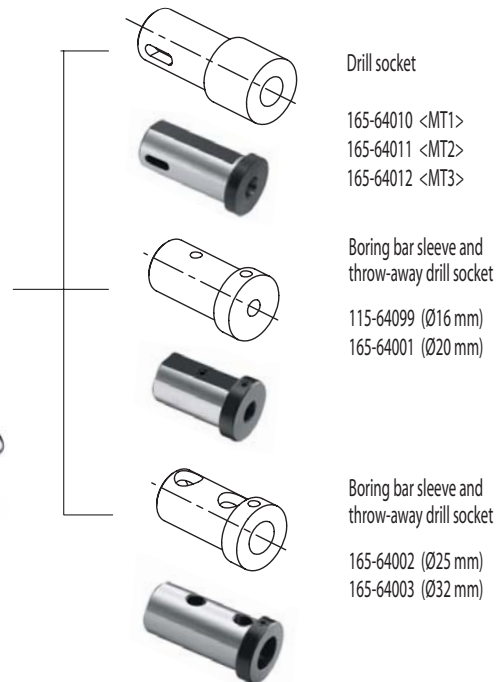

Drill socket

165-64010 <MT1>
165-64011 <MT2>
165-64012 <MT3>

Boring bar sleeve and
throw-away drill socket

115-64099 (Ø16 mm)
165-64001 (Ø20 mm)

Boring bar sleeve and
throw-away drill socket

165-64002 (Ø25 mm)
165-64003 (Ø32 mm)

OKUMA LB15 - LB25
LB15II - LB300

HAAS SL20 - SL30

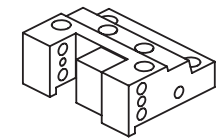

128-42011

Face and O.D. cutting holder

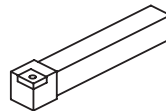

Qualified tool
25x25 mm

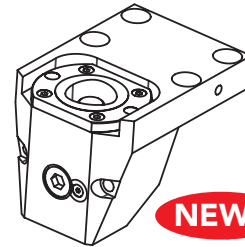

128-12059

Face and O.D. cutting holder
Polygonal C50

NEWS

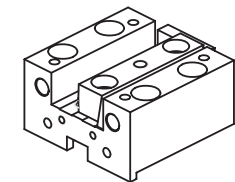

128-32001

Face and I.D. cutting holder



CONNECTION

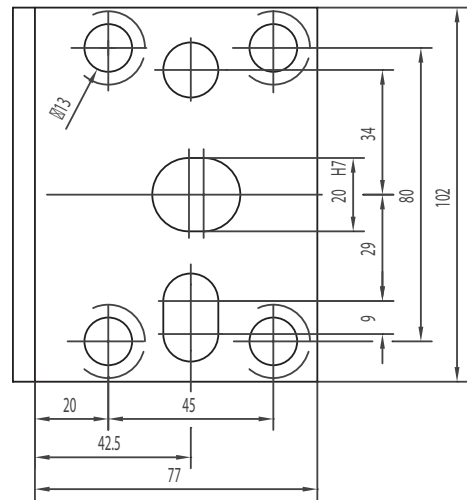

ACCESSORIES

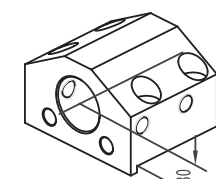

128-22001

Toolholder for boring bar

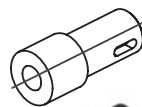

Drill socket

- 165-64010 <MT1>
- 165-64011 <MT2>
- 165-64012 <MT3>



Boring bar sleeve and throw-away drill socket

- 165-64135 (Ø8 mm)
- 165-64013 (Ø10 mm)
- 165-64014 (Ø12 mm)
- 165-64015 (Ø16 mm)
- 165-64016 (Ø20 mm)

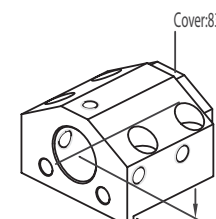

128-22005

Cover:832-003056

Combi toolholder for boring bar and insertdrill with internal coolant

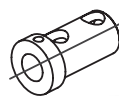

Boring bar sleeve and throw-away drill socket

- 165-64017 (Ø25 mm)
- 165-64018 (Ø32 mm)

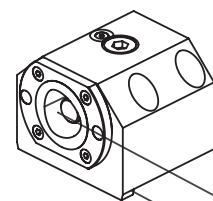

128-12057

Boring bar holder
Polygonal C50

NEWS

OKUMA (HSK63T)

Mac Turn 250/350/400 Multus B250/B300/B400

For turning

ATC Turret (HSK63T)

ICTM STANDARD

45°

90°

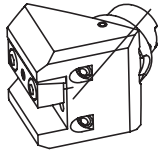

141-11405 25x25 mm

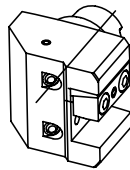

142-11402 25x25 mm

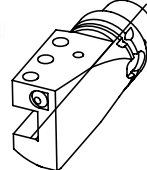

142-21401 (left) 25x25 mm
142-11403 (right)

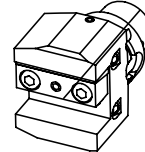

141-11406 25x25 mm

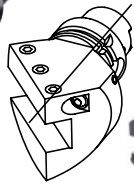

141-11407 (left) 25x25 mm
141-21401 (right)

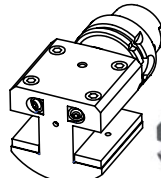

142-11405 32x32/25x25 mm

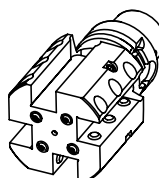

142-21403 20x20 mm (left)
142-21404 20x20 mm (right)

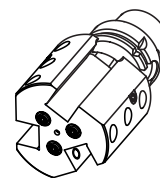

142-21402 20x20 mm (left)
142-11404 20x20 mm (right)

CUT-OFF HOLDER

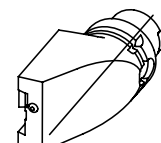

147-51405 (26mm, left)
147-51406 (26mm, right)
147-51407 (32mm, left)
147-51408 (32mm, right)

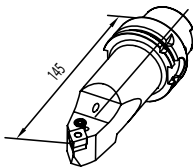

H63APCMNR12-L145

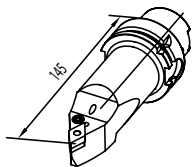

H63APDNNR15-L145



H63ADCM12DDM15-L145

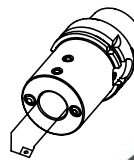

145-21404 (Ø12)
145-21406 (Ø16)
145-21408 (Ø20)
145-21409 (Ø25)
145-21410 (Ø32)
145-21411 (Ø40)

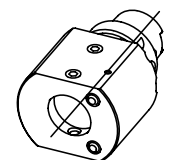

145-21412 Ø40 mm

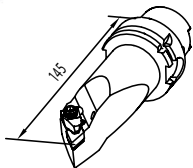

H63ADDMNL15-L145

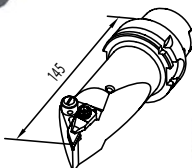

H63ADVMNL16-L145



165-64124 (Ø10 mm)
165-64125 (Ø12 mm)
165-64126 (Ø16 mm)
165-64127 (Ø20 mm)



165-64128 (Ø25 mm)
165-64129 (Ø32 mm)

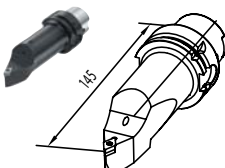

H63ASDNCN11-L145

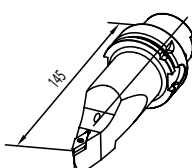

H63ASVVCN16-L145

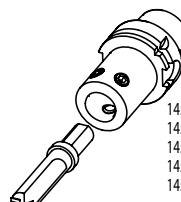

145-11406 (Ø16)
145-11408 (Ø20)
145-11409 (Ø25)
145-11410 (Ø32)
145-11411 (Ø40)



OKUMA
(VDI40)

Mac Turn 250/350

Lower Turret (VDI 40)

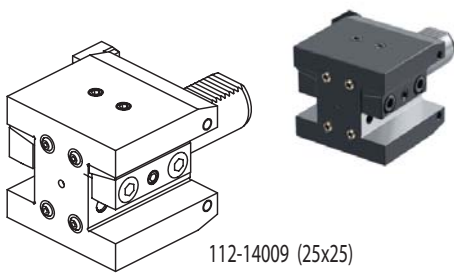

112-14009 (25x25)

ACCESSORIES

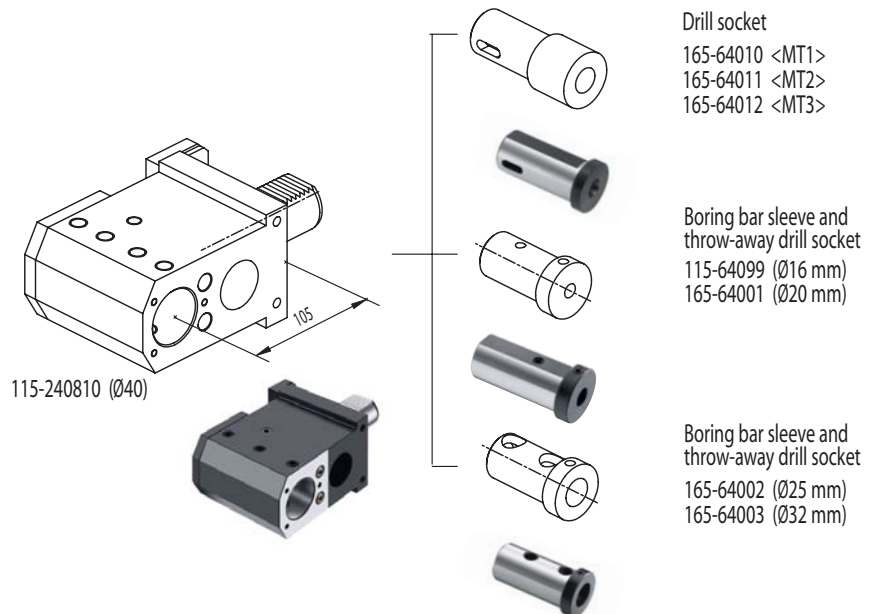

115-240810 (Ø40)

Drill socket
165-64010 <MT1>
165-64011 <MT2>
165-64012 <MT3>

Boring bar sleeve and
throw-away drill socket
115-64099 (Ø16 mm)
165-64001 (Ø20 mm)

Boring bar sleeve and
throw-away drill socket
165-64002 (Ø25 mm)
165-64003 (Ø32 mm)

OKUMA (HSK100A)

Mac Turn 550

For turning

ATC Turret (HSK100A) ICTM STANDARD

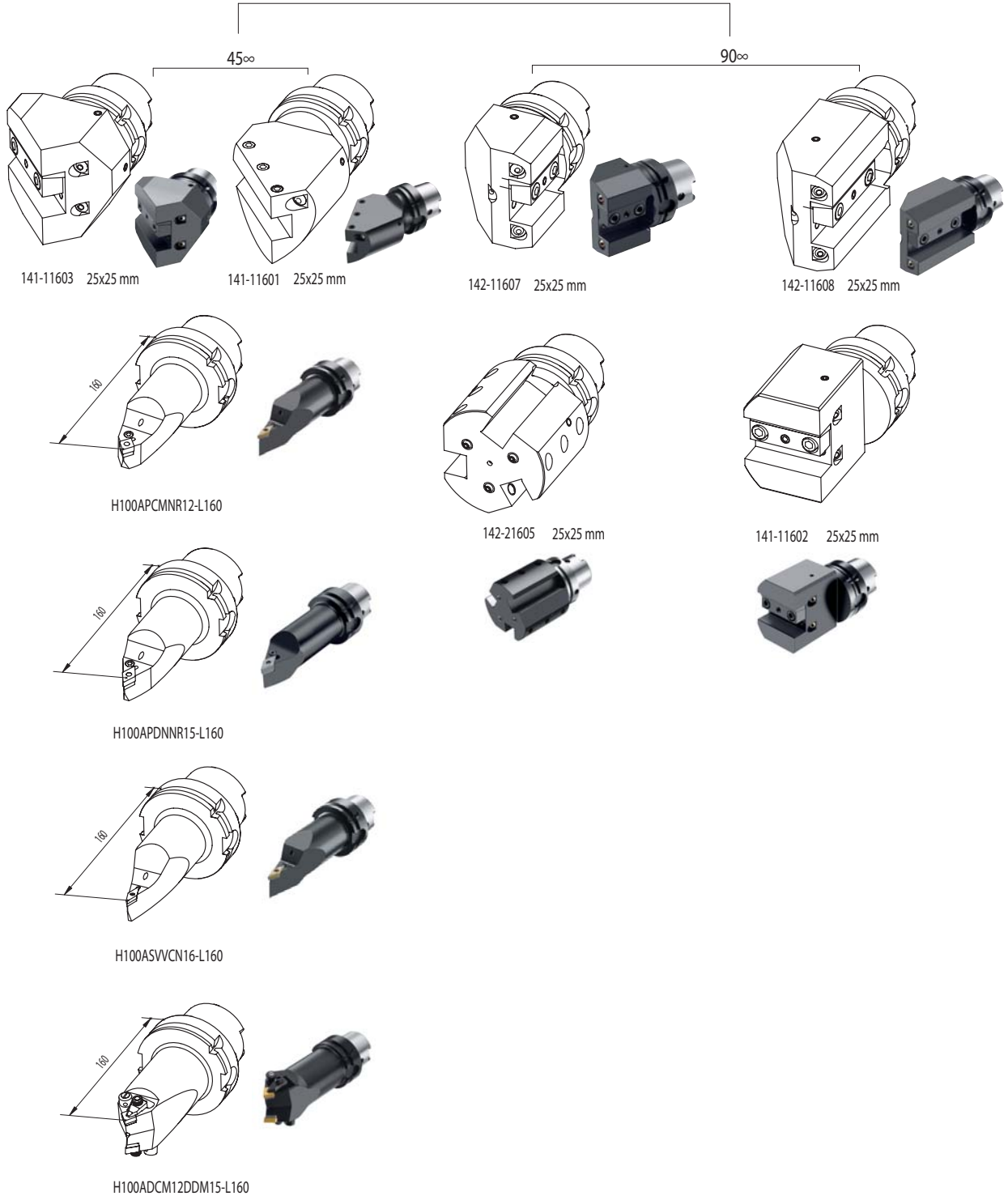

OKUMA (BMT60)

LB2500 EX (M) LB3000 EX (M, MY)

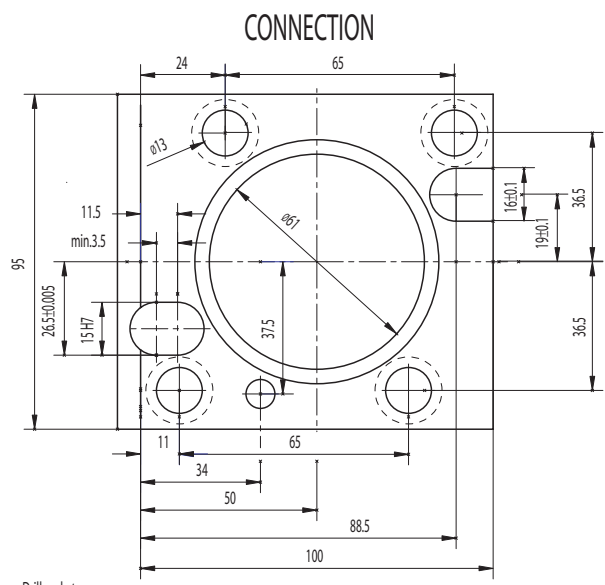
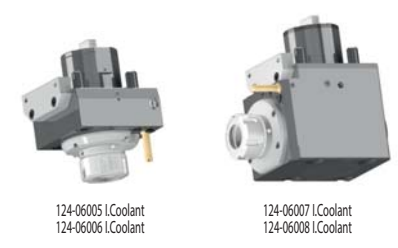
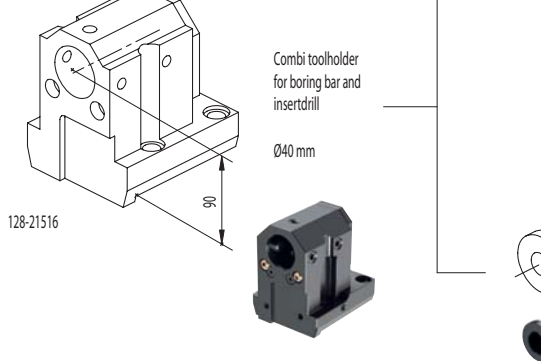
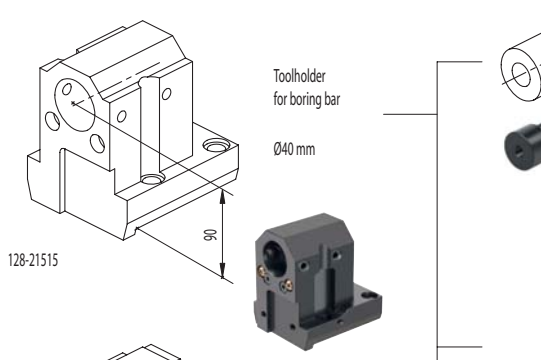
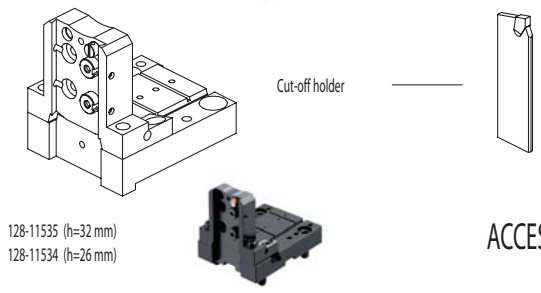
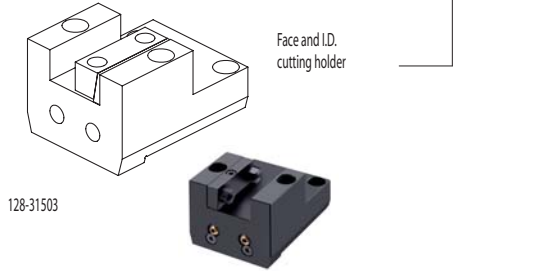
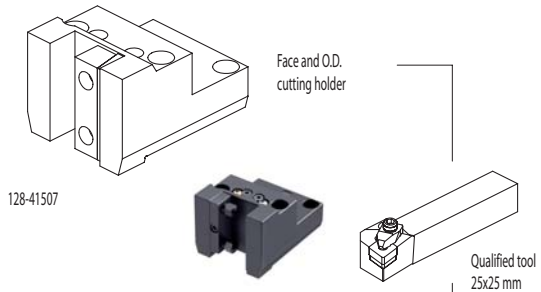

ACCESSORIES



OKUMA (BMT60)

LB3000 EX (MW, MYW)

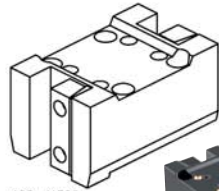

128-41509

Face and O.D.
cutting holder

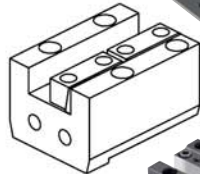

128-31505

Face and I.D.
cutting holder

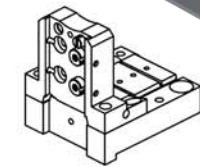

128-11535 (h=32 mm)

Cut-off holder

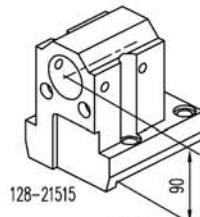

128-21515

Toolholder
for boring bar

Ø40 mm

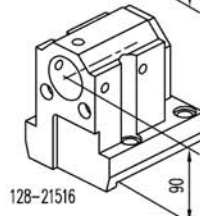

128-21516

Combi toolholder
for boring bar and
insertdrill

Ø40 mm

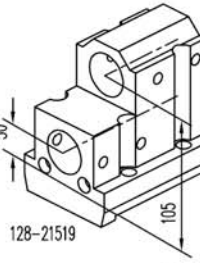

128-21519

Double toolholder
for boring bar

Ø40 mm

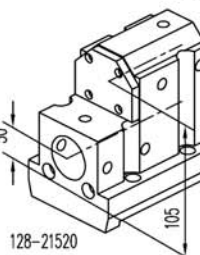

128-21520

Double combi toolholder
for boring bar and
insertdrill

Ø40 mm

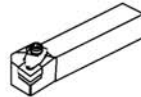

Qualified tool
25x25 mm



124-06005 I.Coolant
124-06006 I.Coolant



124-06007 I.Coolant
124-06008 I.Coolant



Cut-off tool
32 mm
26 mm

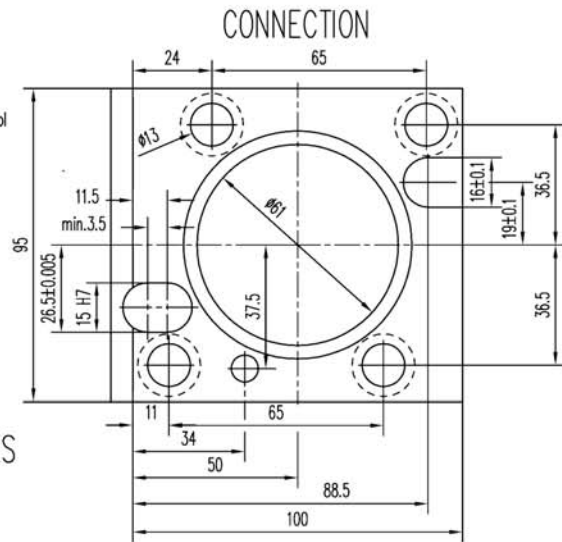

ACCESSORIES

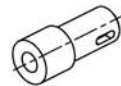

Drill socket

165-64011 <MT2>
165-64012 <MT3>



Boring bar sleeve

165-64013 (Ø10 mm)
165-64014 (Ø12 mm)
165-64015 (Ø16 mm)
165-64016 (Ø20 mm)



Throw-away drill socket

165-64205 (Ø25 mm)
165-64206 (Ø32 mm)

OKUMA (BMT60)

LB4000 EX (M, MY)

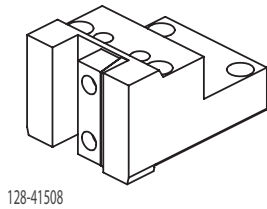

128-41508

Face and O.D. cutting holder

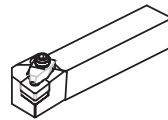

Qualified tool
25x25 mm



124-06009 I.Coolant
124-06010 I.Coolant



124-06011 I.Coolant
124-06012 I.Coolant

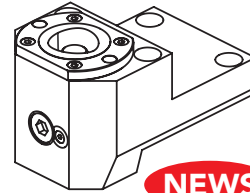

128-11562

Face and O.D. cutting holder

Poligonal C50

NEWS

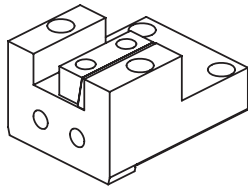

128-31504

Face and I.D. cutting holder

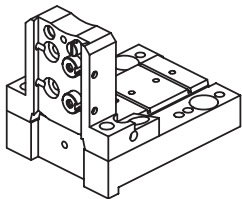

128-11536

Cut-off holder



Cut-off tool
32 mm

CONNECTION

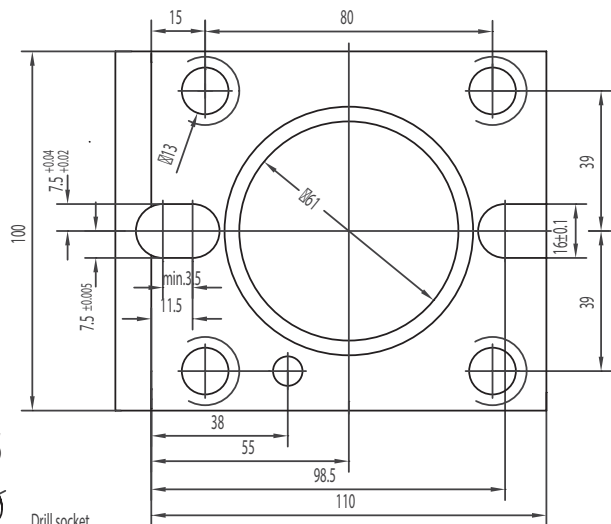

ACCESSORIES

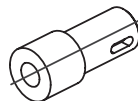

Drill socket

- 165-64010 <MT1>
- 165-64011 <MT2>
- 165-64012 <MT3>



Boring bar sleeve

- 165-64135 (Ø8 mm)
- 165-64013 (Ø10 mm)
- 165-64014 (Ø12 mm)
- 165-64015 (Ø16 mm)
- 165-64016 (Ø20 mm)

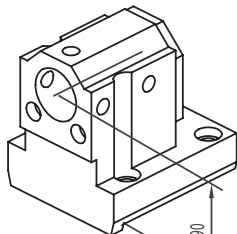

128-21518

Combi toolholder for boring bar and insert drill

Ø40 mm

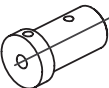

Throw-away drill socket

- 165-64203 (Ø16 mm)
- 165-64204 (Ø20 mm)
- 165-64205 (Ø25 mm)
- 165-64206 (Ø32 mm)

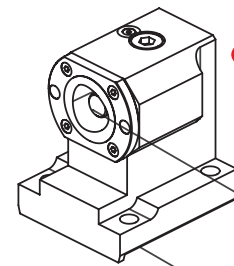

128-11560

NEWS

Boring bar holder

Poligonal C50

NAKAMURA TOME

TW10

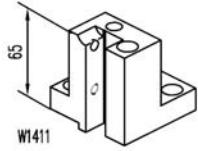

W1411

Face and O.D. cutting holder

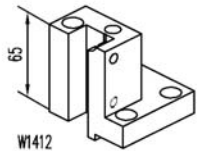

W1412

Face and O.D. cutting holder

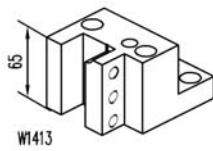

W1413

Face and O.D. cutting holder

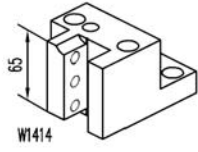

W1414

Face and O.D. cutting holder

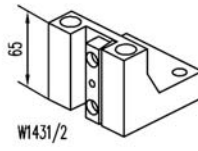

W1431/2

Face and O.D. cutting holder

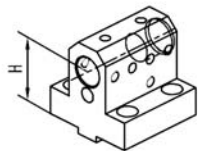

W1417 D25 (H=55 mm)
W4437 D25 (H=75 mm)

Combi toolholder for boring bar and insertdrill

Ø25 mm

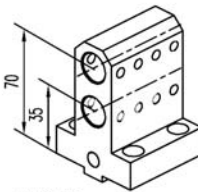

W1418 D25

Double toolholder for boring bar

Ø25 mm



124-05507 I.Coolant
124-05508 I.Coolant



124-05509 I.Coolant
124-05510 I.Coolant

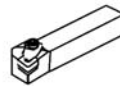

Qualified tool
20x20 mm

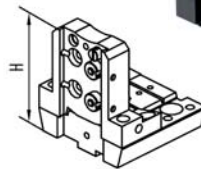

121-22076 (h=32 mm H=100 mm)



Cut-off holder



Cut-off tool

CONNECTION

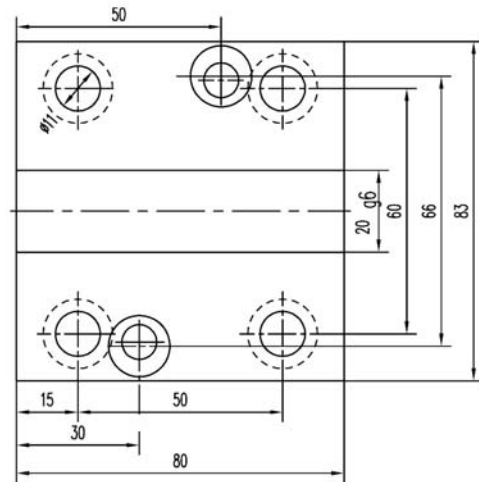

NAKAMURA TOME

TW20 - WT300 - SC300

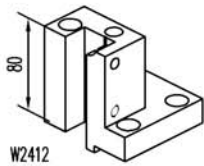

W2412



Face and O.D.
cutting holder
25x25 mm

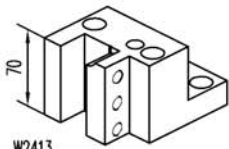

W2413



Face and O.D.
cutting holder
25x25 mm

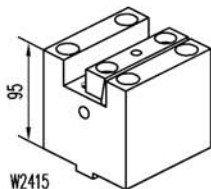

W2415



Face and I.D.
cutting holder
25x25 mm

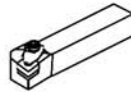

Qualified tool



124-06504 I.Coolant
124-06505 I.Coolant



124-06506 I.Coolant
124-06507 I.Coolant

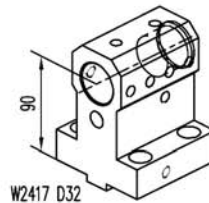

W2417 D32

Combi toolholder
for boring bar and
insertdrill

∅32 mm



CONNECTION

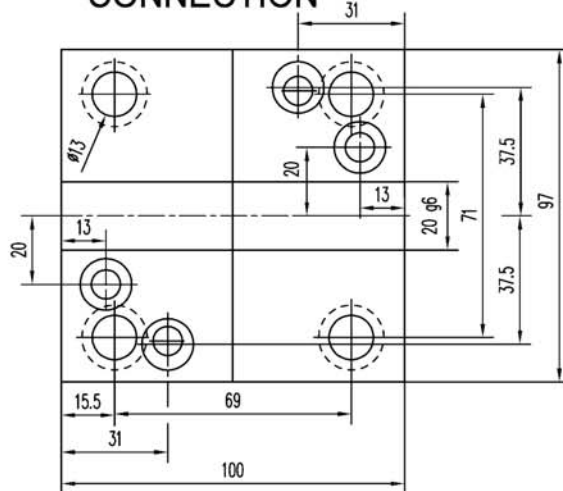

NAKAMURA TOME (BMT65)

WT100

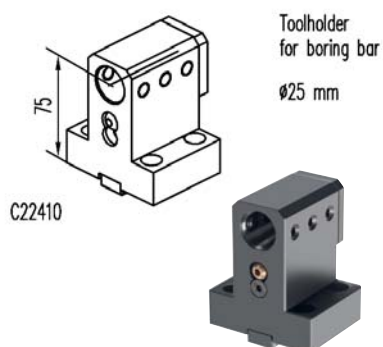
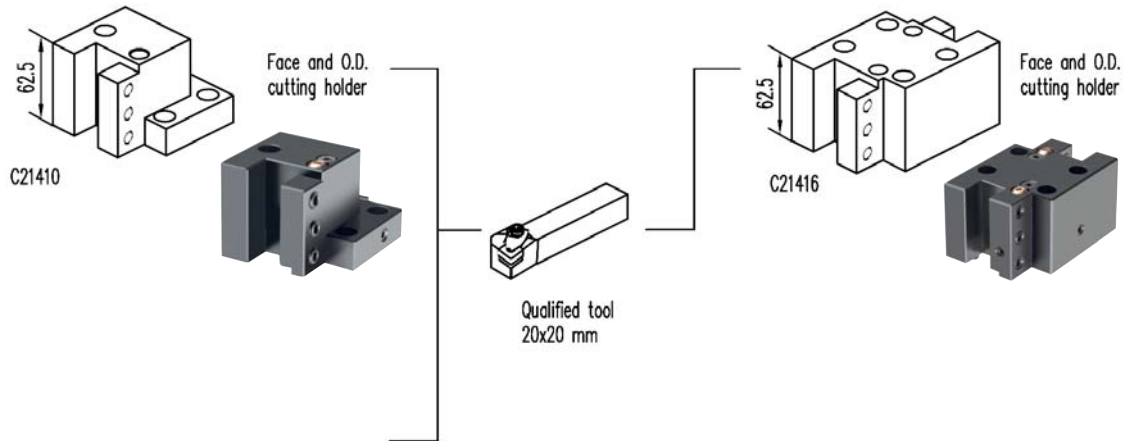

CONNECTION

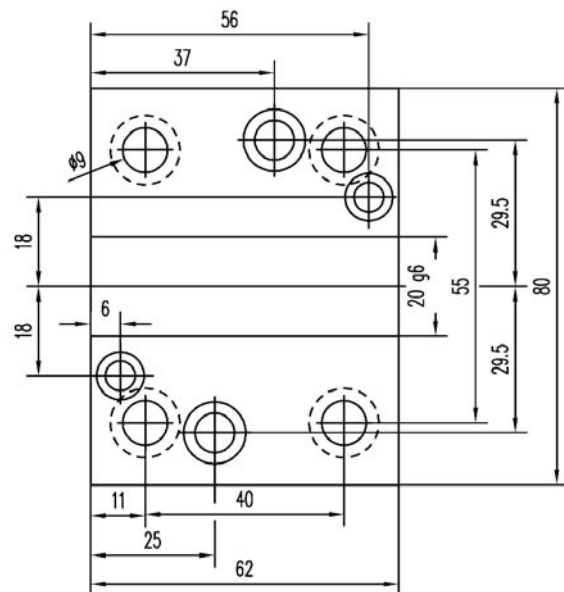

NAKAMURA TOME (BMT55)

WT150 - WTW150 - WTS150
WT250 - SC150 - SC250

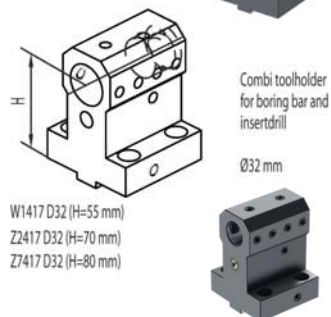
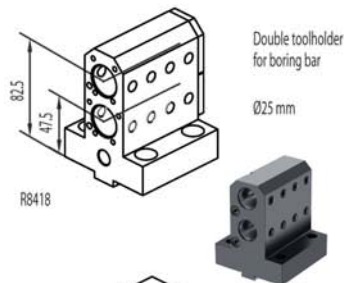
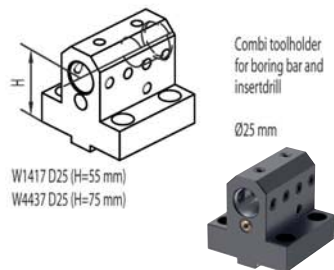
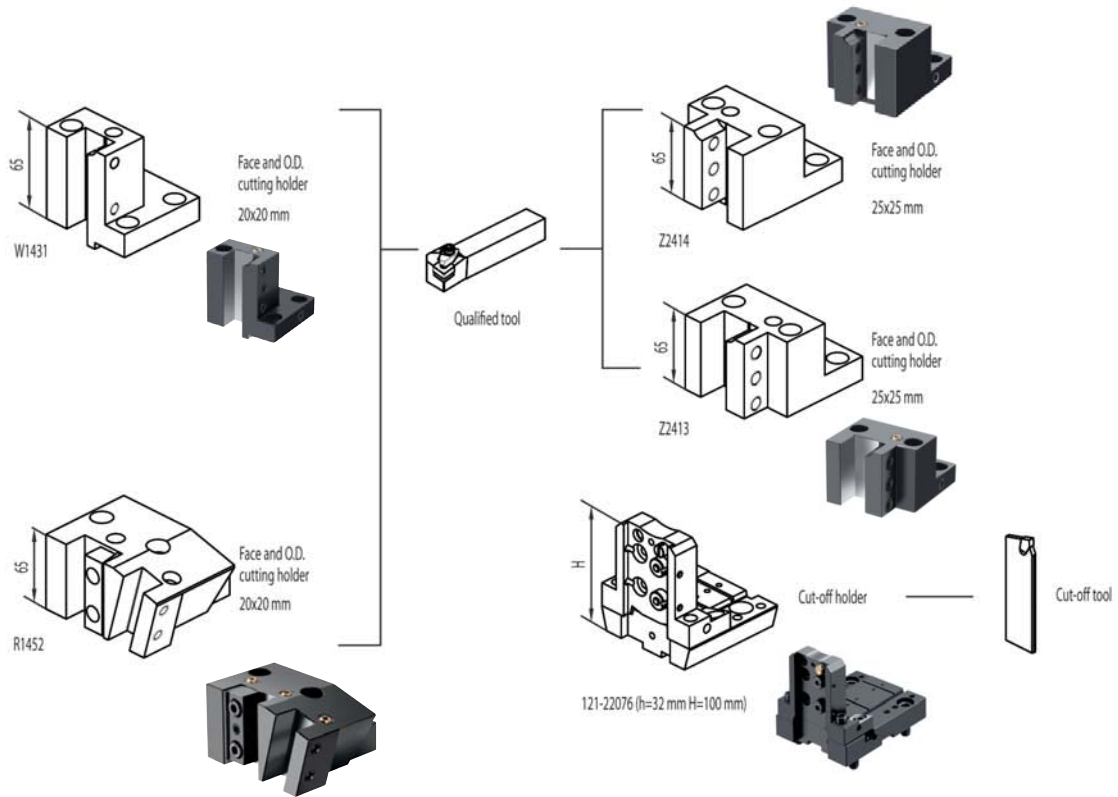

CONNECTION

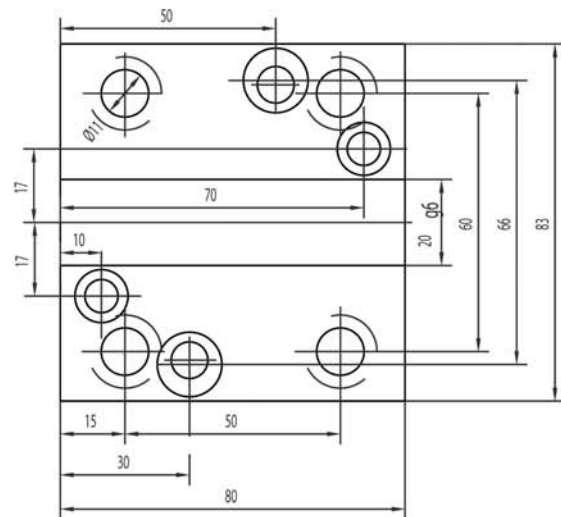

DOOSAN PUMA

230M/MS - 240M/MS

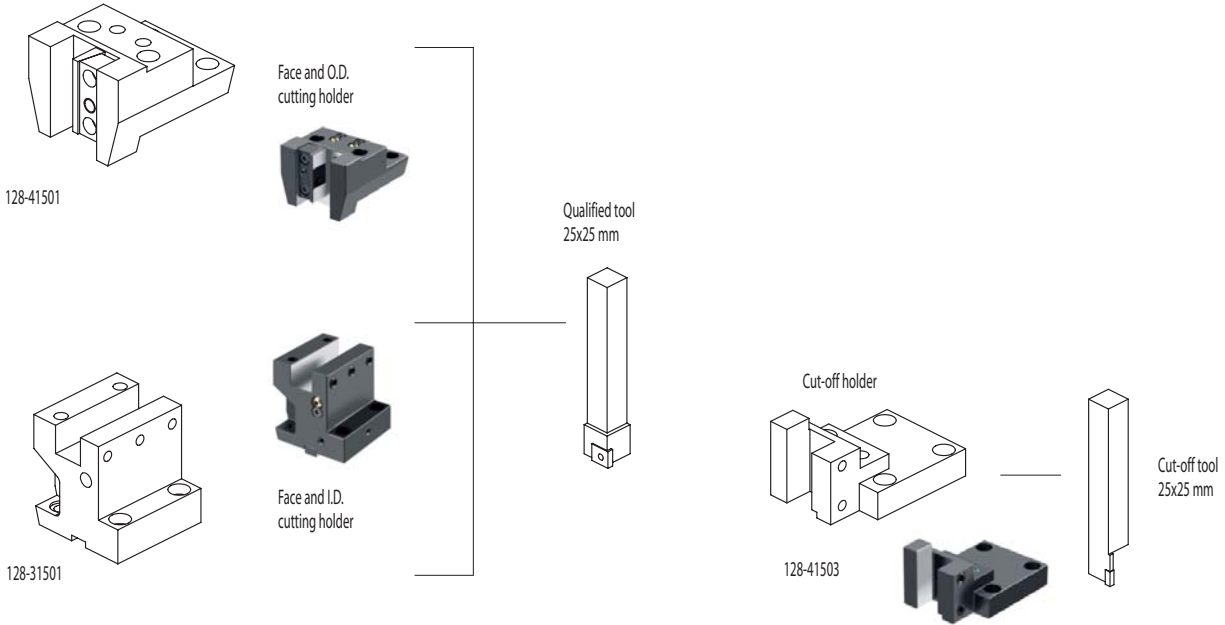

ACCESSORIES

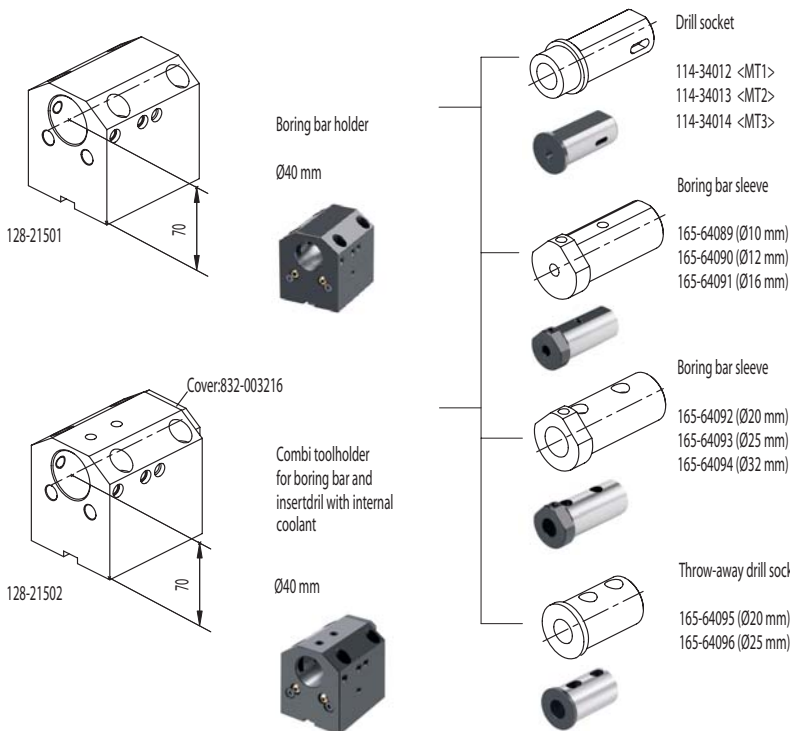

CONNECTION

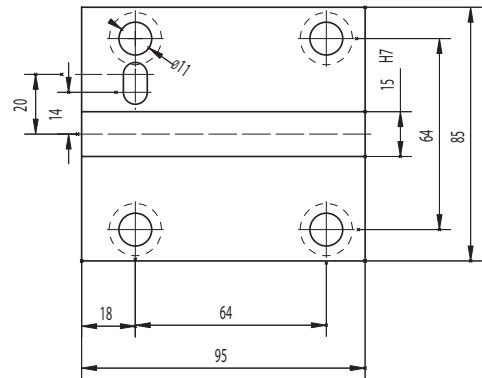

DOOSAN PUMA

230S - 240S - LYNX210

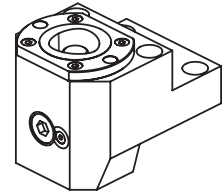
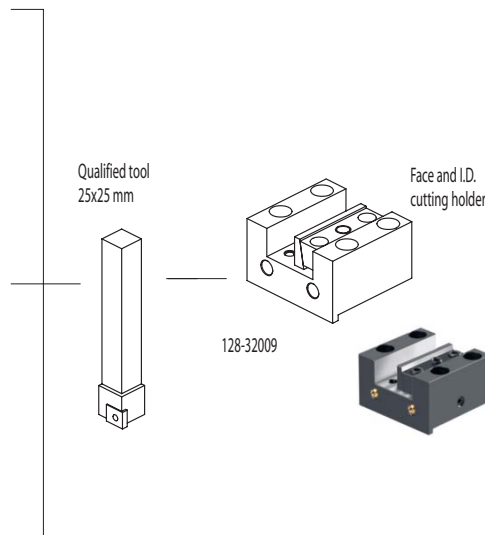
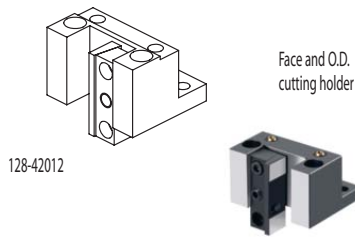
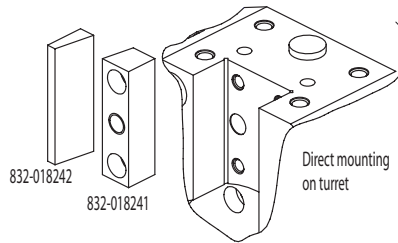

NEWS

CONNECTION

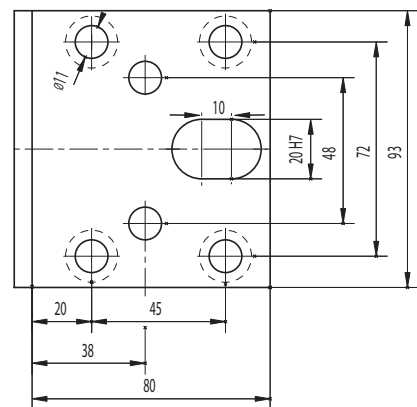

ACCESSORIES

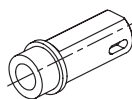
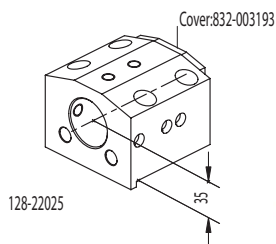
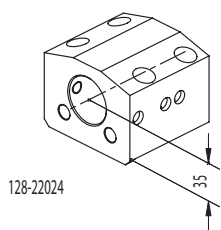

- 114-34013 <MT2>
- 114-34014 <MT3>



- 165-64090 (Ø12 mm)
- 165-64091 (Ø16 mm)

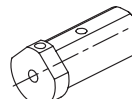

- 165-64093 (Ø25 mm)
- 165-64094 (Ø32 mm)



- 165-64096 (Ø25 mm)
- Throw-away drill socket
- 165-64095 (Ø20 mm)
- 165-64096 (Ø25 mm)

DOOSAN (BMT45)

LYNX 220LM

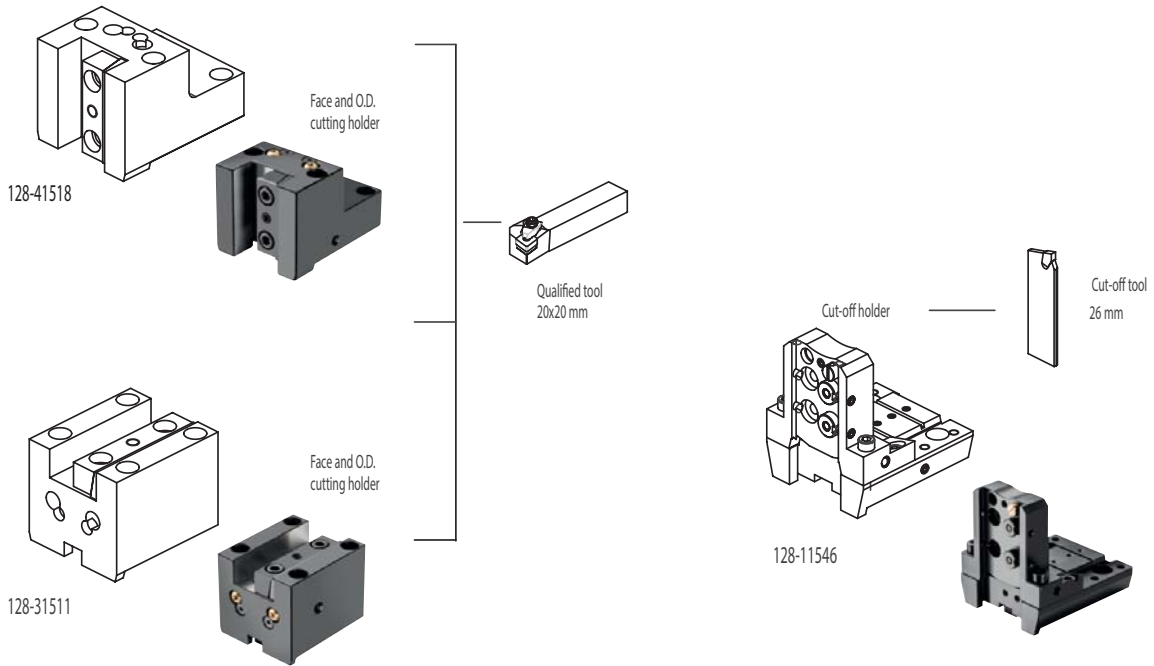

ACCESSORIES

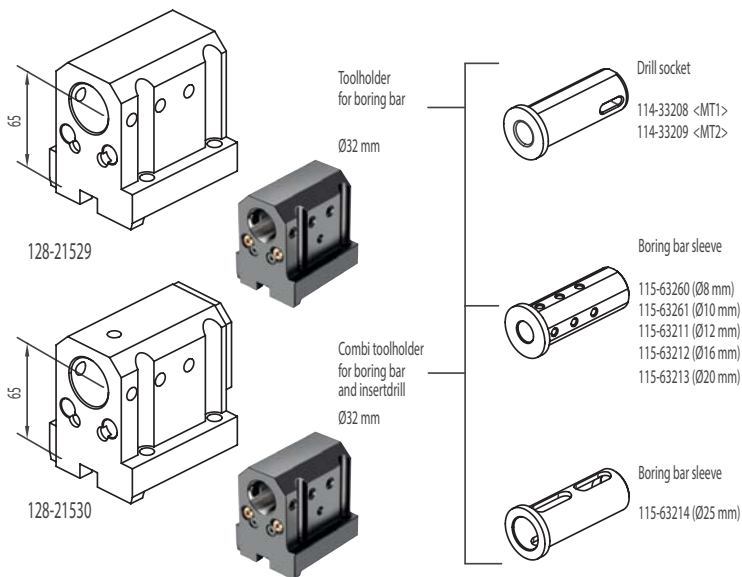

CONNECTION

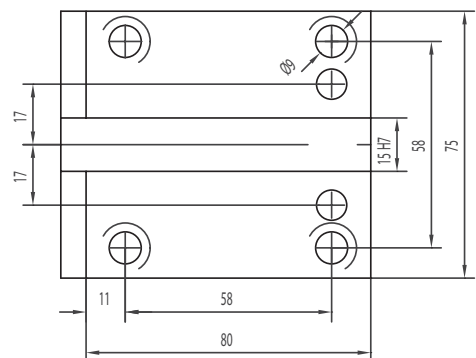

DOOSAN
(BMT55)

DOOSAN
(BMT55)

PUMA 230-240M/MS - 280LM - 1500-2000-2500M/MS/Y/SY
2100 SERIE - TT1500-TT1800MS/SY
TL2000-2500LM - MX1600/2100TS
LYNX 300M

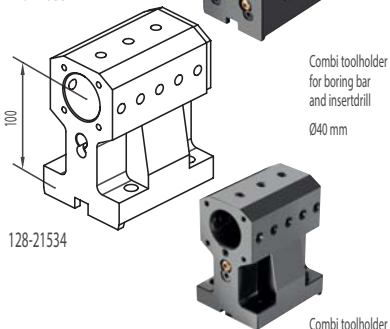
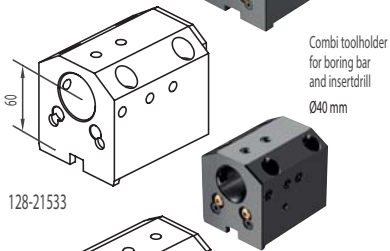
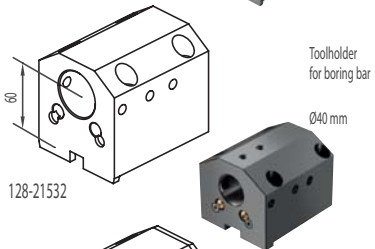
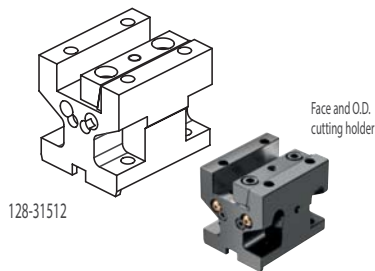
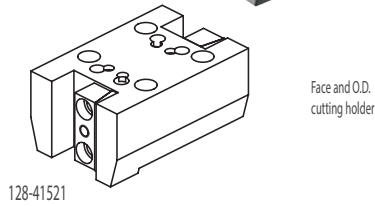
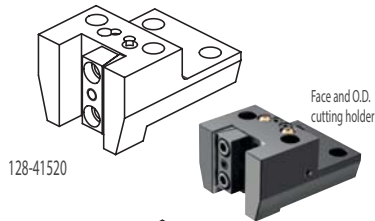

Face and O.D. cutting holder

Face and O.D. cutting holder

Face and O.D. cutting holder

Toolholder for boring bar

Combi toolholder for boring bar and insertdrill

Combi toolholder for boring bar and insertdrill

Combi toolholder for boring bar and insertdrill

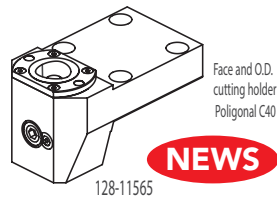

NEWS

ACCESSORIES

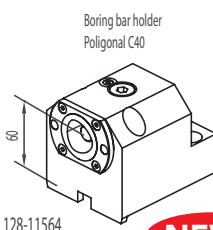
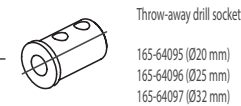
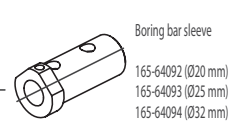
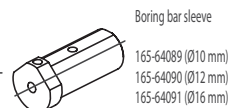
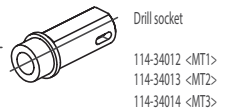

NEWS

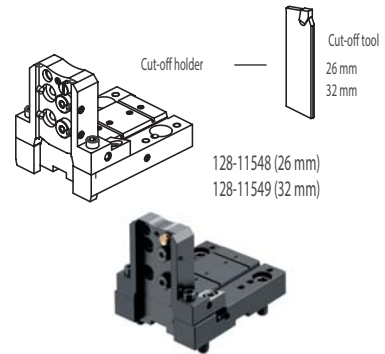

Driven tools

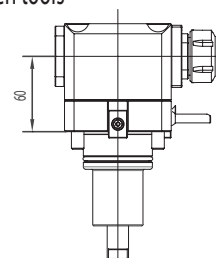
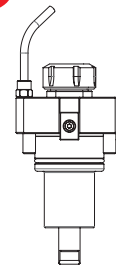

CONNECTION

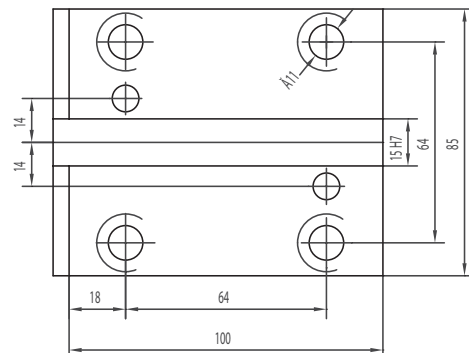

DOOSAN PUMA (BMT65)

300M/MS - V400M - TT2000SY - TT2500SY
TT2500MS - 2600/3100 SERIE
MX2000ST - MX2500T/ST/LST - VT450/TM
INVERTURN 300M

Face and O.D. cutting holder

128-41801

128-41802

128-31802

128-21801

128-21802

128-21803

128-11805

128-11807

Qualified tool 25x25 mm

128-11809

Face and O.D. cutting holder

128-41803

Face and O.D. cutting holder

128-41804

Face and O.D. cutting holder Polygonal CS0

128-11804

Cut-off holder

Cut-off tool 32 mm

ACCESSORIES

Toolholder for boring bar Ø40 mm

Combi toolholder for boring bar and insertdrill Ø40 mm

Combi toolholder for boring bar and insertdrill Ø40 mm

Boring bar holder Polygonal CS0

Boring bar holder double Polygonal CS0

Drill socket

114-34012 <MT1>
114-34013 <MT2>
114-34014 <MT3>

Boring bar sleeve

165-64089 (Ø10 mm)
165-64090 (Ø12 mm)
165-64091 (Ø16 mm)

Boring bar sleeve

165-64092 (Ø20 mm)
165-64093 (Ø25 mm)
165-64094 (Ø32 mm)

Throw-away drill socket

165-64095 (Ø20 mm)
165-64096 (Ø25 mm)
165-64097 (Ø32 mm)

Driven tools

124-06501

124-06502

124-06508 I.Coolant

124-06512 I.Coolant

CONNECTION

18

Ø13

17

17

92

20

70

110

18 H7

73

95

NEWS

NEWS

DOOSAN PUMA (BMT75)

400 - 480M/LM/XLM - VT 750M/TM

CONNECTION

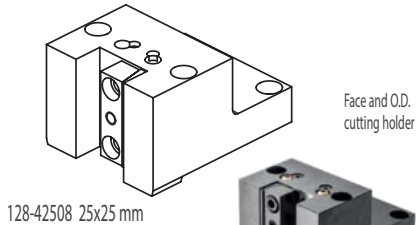

Face and O.D. cutting holder

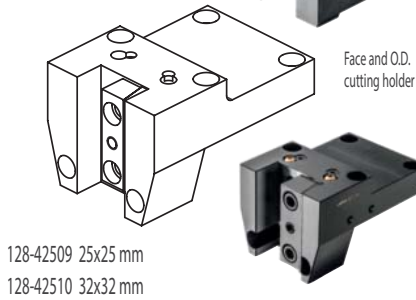

Face and O.D. cutting holder

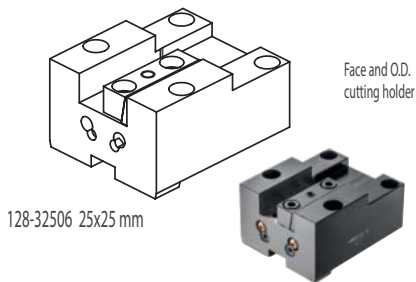

Face and O.D. cutting holder

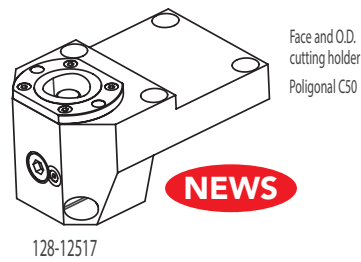
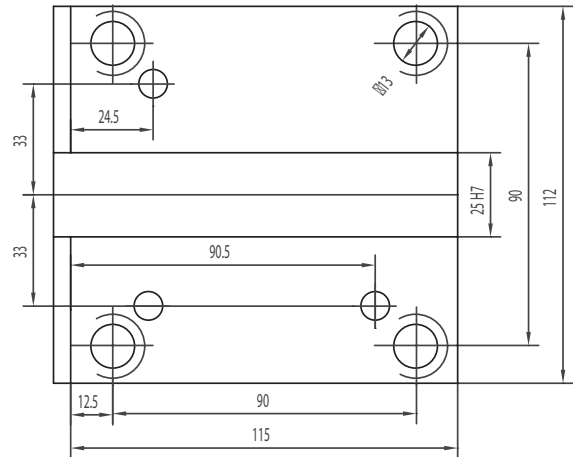
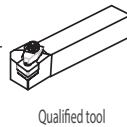

Face and O.D. cutting holder
Polygonal C50

NEWS

ACCESSORIES

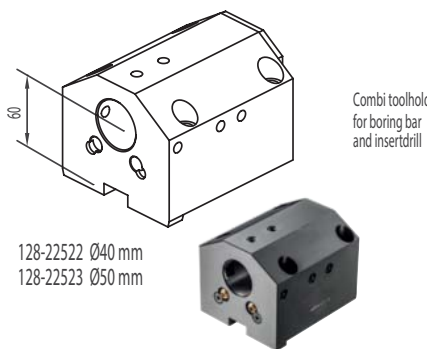

Combi toolholder for boring bar and insertdrill

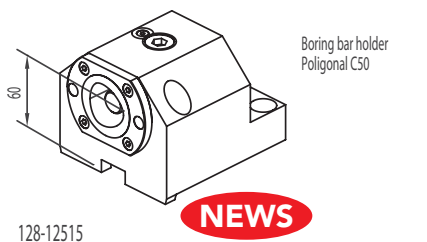

Boring bar holder
Polygonal C50

NEWS

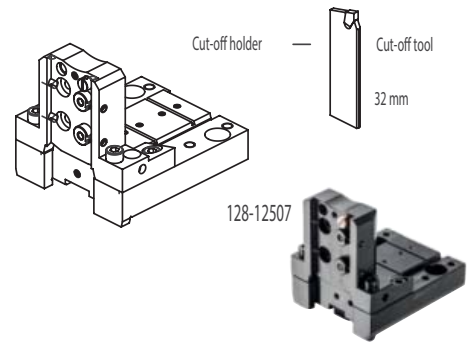
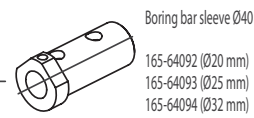
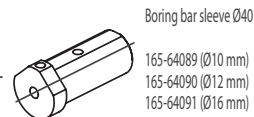
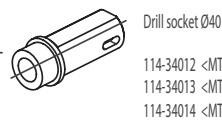

DOOSAN PUMA (BMT85)

600M/LM - 700M/LM - 800M/LM
VT900M/TM- VT1100M

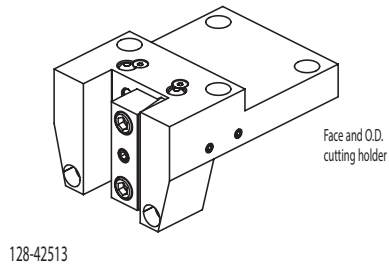

Face and O.D. cutting holder

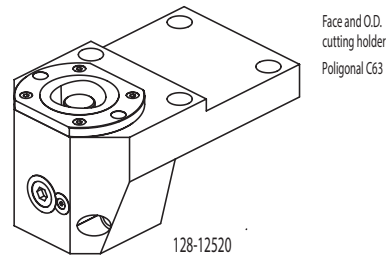

Face and O.D. cutting holder
Polygonal C63

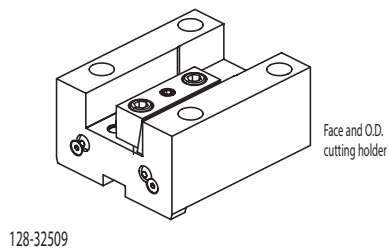

Face and O.D. cutting holder

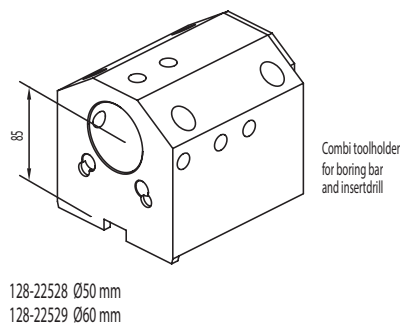
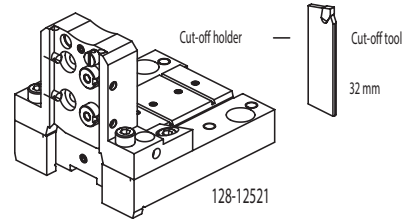
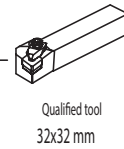

Combi toolholder
for boring bar
and insertdrill

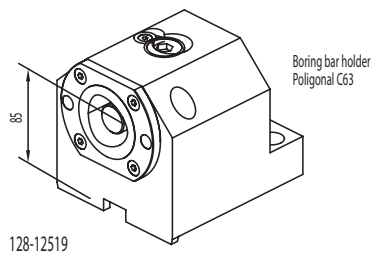

Boring bar holder
Polygonal C63

CONNECTION

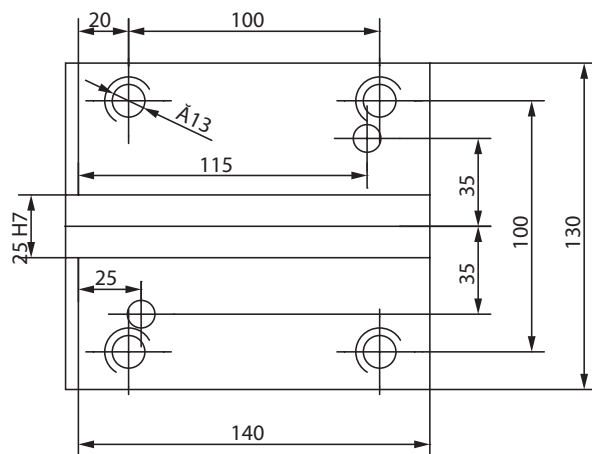

MAZAK NEXUS

SQT100/150

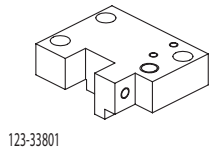

123-33801

Face and O.D. cutting holder

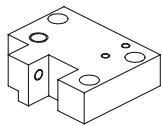

123-33802

Face and O.D. cutting holder



Qualified tool
20x20 mm

CONNECTION

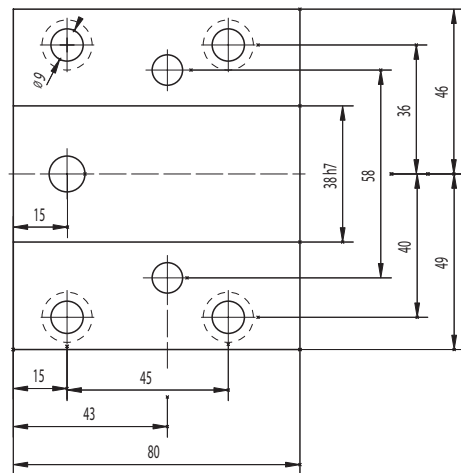

ACCESSORIES

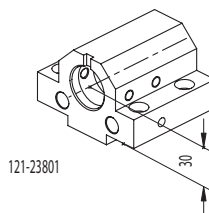

121-23801

Boring bar holder



Ø32 mm

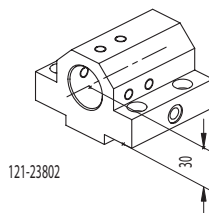

121-23802

Toolholder for insertdrill with internal coolant



Ø32 mm



Drill socket
114-33216 <MT2>



Boring bar sleeve
165-63241 (Ø8 mm)
165-63242 (Ø10 mm)
165-63243 (Ø12 mm)
165-63244 (Ø16 mm)

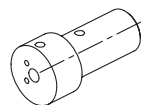

Boring bar sleeve
165-63245 (Ø20 mm)
165-63246 (Ø25 mm)

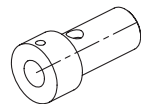

MAZAK NEXUS

QTN200/250

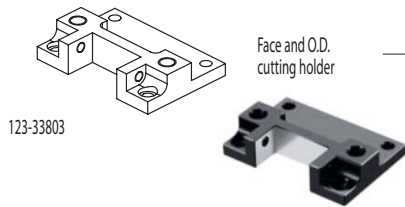

123-33803

Face and O.D. cutting holder

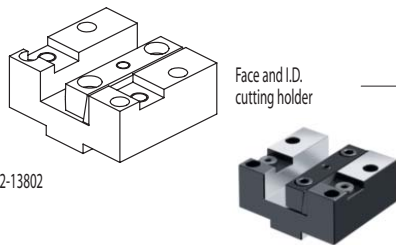

122-13802

Face and I.D. cutting holder



Qualified tool
25x25 mm

CONNECTION

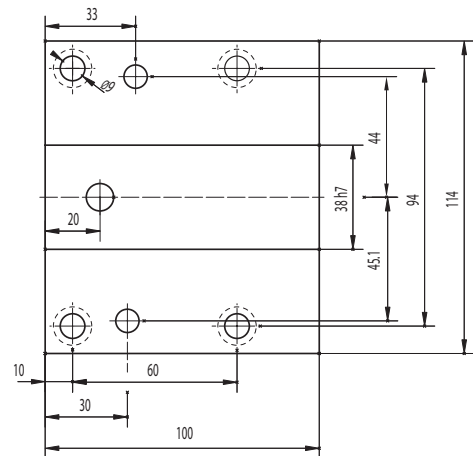

ACCESSORIES

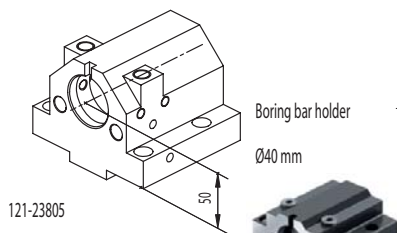

121-23805

Boring bar holder
Ø40 mm

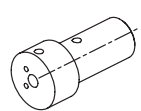

Boring bar sleeve

- 165-64114 (Ø8 mm)
- 165-64115 (Ø10 mm)
- 165-64116 (Ø12 mm)
- 165-64117 (Ø16 mm)
- 165-64118 (Ø20 mm)

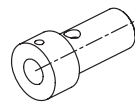

Boring bar sleeve

- 165-64119 (Ø25 mm)
- 165-64120 (Ø32 mm)

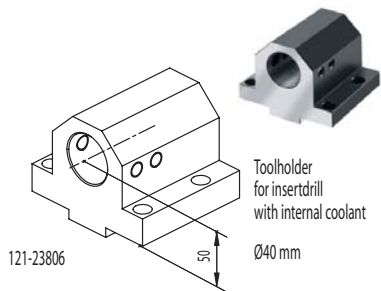

121-23806

Toolholder for insert drill with internal coolant
Ø40 mm

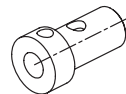

Throw-away drill socket

- 165-64121 (Ø20 mm)
- 165-64122 (Ø25 mm)
- 165-64123 (Ø32 mm)



MAZAK SQT
MAZAK QTN
(VDI40)

SQT 15, SQT 18 M / MS - 12 Stations
SQT 200, SQT 250 M / MS - 12 Stations
QTN 200, QTN 250 M / MB / MS / MY / MSY - 12 Stations

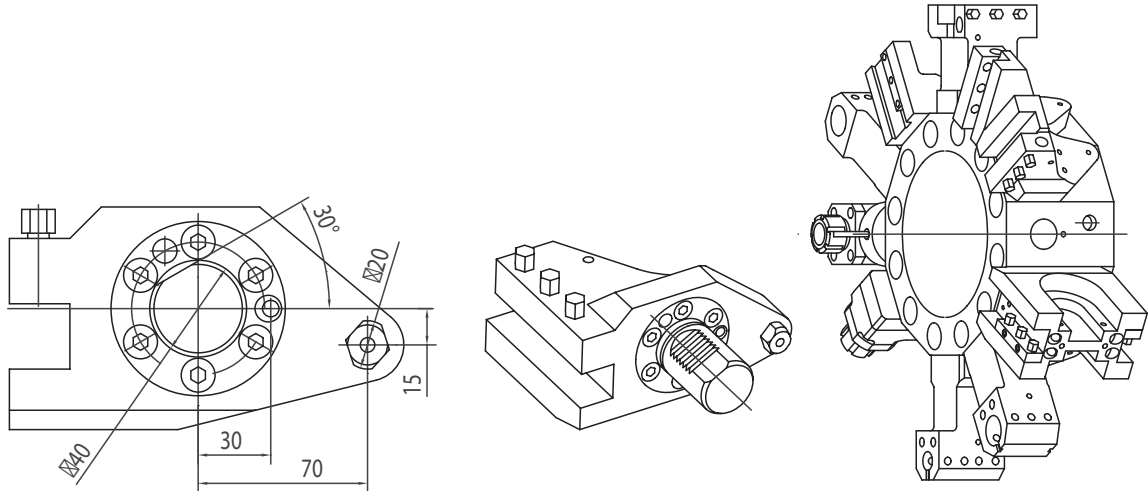

Qualified tool
25x25 mm

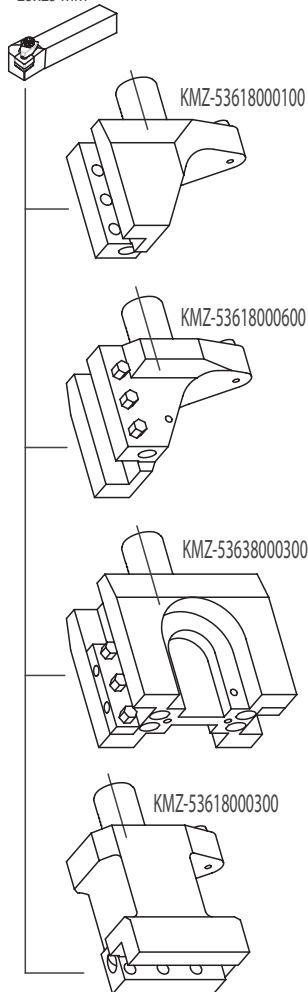

ACCESSORIES

Drill socket

- 114-34015 <MT1>
- 114-34016 <MT2>
- 114-34017 <MT3>

Boring bar sleeve

- 165-64114 (Ø8 mm)
- 165-64115 (Ø10 mm)
- 165-64116 (Ø12 mm)
- 165-64117 (Ø16 mm)
- 165-64118 (Ø20 mm)

Boring bar sleeve

- 165-64119 (Ø25 mm)
- 165-64120 (Ø32 mm)

Throw-away drill socket

- 165-64121 (Ø20 mm)
- 165-64122 (Ø25 mm)
- 165-64123 (Ø32 mm)

Cut-off tool
32 mm

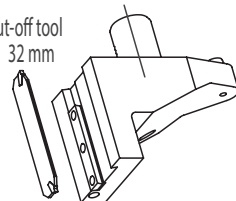

KMZ-53618000400

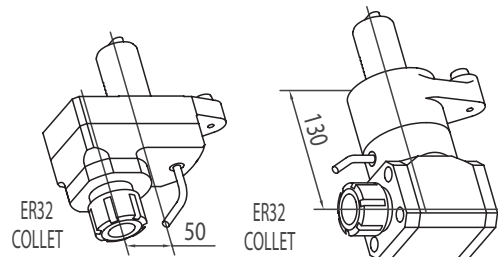
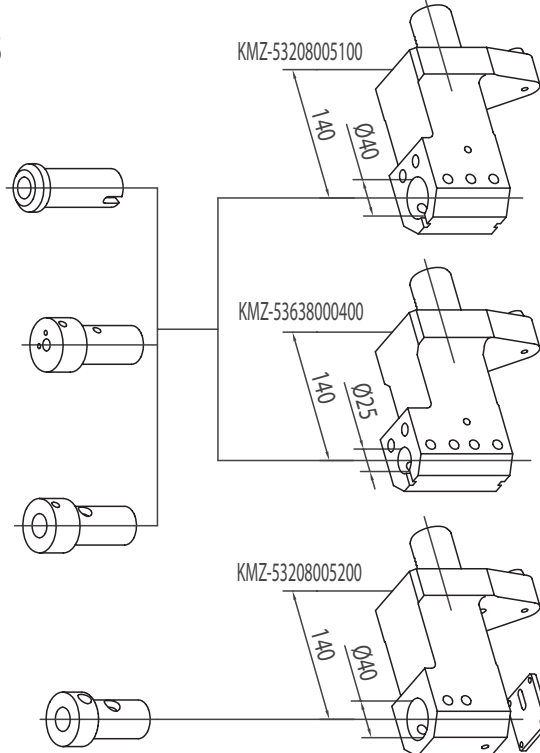

WFL
(HSK100)

Millturn 120

ICTM STANDARD

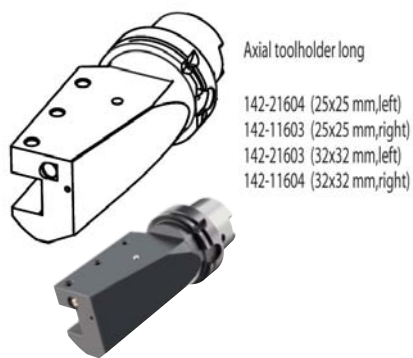
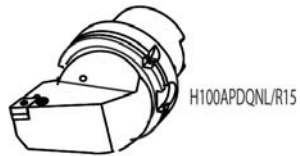

GOODWAY (BMT60)

GS2000 SERIES - GS3000 SERIES GS4000 SERIES

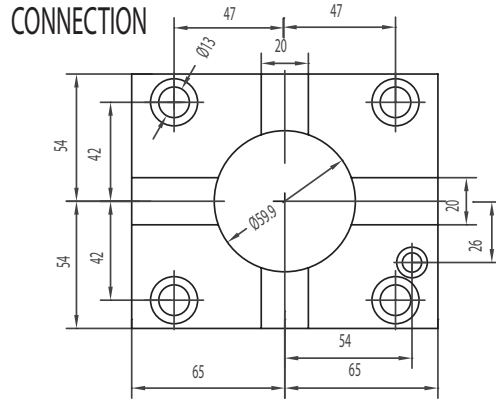
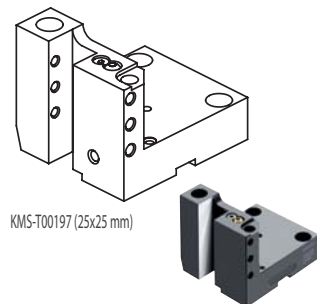
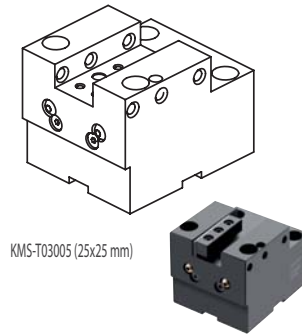
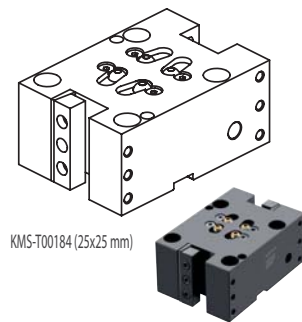
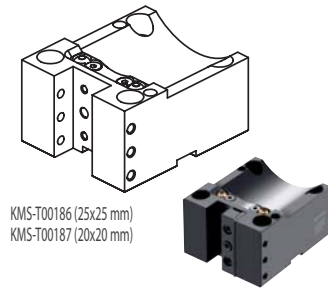
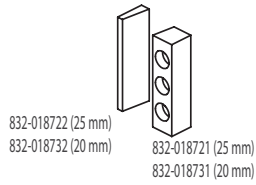

Driven tools

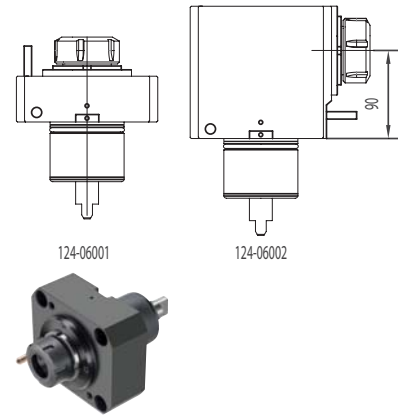

ACCESSORIES

- KMS-T20098-A (Ø32 mm)
- KMS-T20096-A (Ø25 mm)
- KMS-T20094-A (Ø20 mm)
- KMS-T20092-A (Ø16 mm)
- KMS-T20090-A (Ø12 mm)
- KMS-T20088-A (Ø10 mm)
- KMS-T20086-A (Ø8 mm)

- KMS-T20196-A (Ø20 mm)
- KMS-T20194-A (Ø16 mm)
- KMS-T20110-A (Ø12 mm)
- KMS-T20108-A (Ø10 mm)
- KMS-T20106-A (Ø8 mm)

- KMS-T22042-A (MT3)
- KMS-T22044-A (MT4)
- KMS-T22046-A (MT2)
- KMS-T22066-A (MT1)

- KMS-T20122-A (Ø25 mm)
- KMS-T20120-A (Ø20 mm)
- KMS-T20118-A (Ø16 mm)
- KMS-T20116-A (Ø12 mm)
- KMS-T20114-A (Ø10 mm)
- KMS-T20112-A (Ø8 mm)

- KMS-T20100-A (Ø32 mm)
- KMS-T20102-A (Ø25 mm)
- KMS-T20104-A (Ø20 mm)
- KMS-T20190-A (Ø16 mm)

