

KINTEK

COMPONENTI INNOVATIVI TECNOMECCANICI

**TOOLHOLDERS FOR CNC LATHES
(BMT, BOLT-ON, VDI DIN69880)**



**CNC-DREHEMASCHINEN
(BMT, BOLT-ON, VDI DIN69880)**



**РЕЗЦЕДЕРЖАТЕЛИ ДЛЯ
ТОКАРНЫХ СТАНКОВ С ЧПУ
(BMT, BOLT-ON, VDI DIN69880)**



**PORTE-OUTILS POUR TOURS CNC
(BMT, BOLT-ON, VDI DIN69880)**



**PORTAUTENSILI PER TORNII CNC
(BMT, BOLT-ON, VDI DIN69880)**



**数控车床刀柄
BMT, BOLT-ON, VDI DIN69880**



DMG MORI TOOLHOLDERS

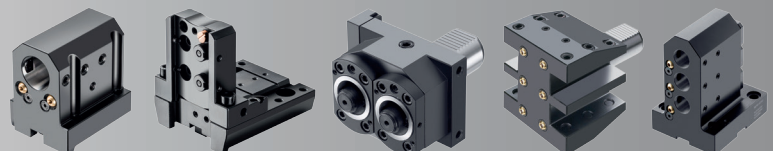

SPECIAL TOOLHOLDERS



KINTEK srl

Via Goretta 88/G - 10072 MAPPANO Fraz. di Caselle - (TO) ITALIA
Tel. +39.011.9968065 - Fax +39.011.9965662 - E-mail: info@kintek.it

<http://www.kintek.it>

DMG MORI
(VDI30)

CTX 210/310/410 V3/V1 - CTX 320/420 V3
CTX Alpha 300/500 V3
CTX Beta 500/800/1250 V3 (option)
CTV 160

AXIAL TURRET

Face and O.D. cutting holder
B1-30x20x40

Face and O.D. cutting holder overhead
B3-30x20x40

Face and O.D. cutting holder
B5-30x20x40

Face and O.D. cutting holder overhead
B7-30x20x40

Cut-off holder
26 mm
AR3026

Bar puller
KH1-30

VDI damped, adjustable, stop bar
MW-3042-AM

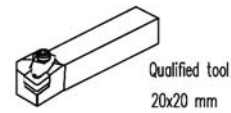
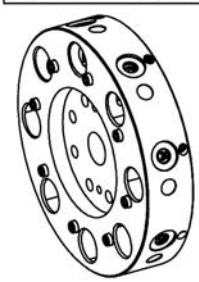

ACCESSORIES

E2-115

Boring bar sleeve $\varnothing 25$ mm

115-62574 ($\varnothing 8$ mm)
115-62575 ($\varnothing 10$ mm)
115-62576 ($\varnothing 12$ mm)
115-62577 ($\varnothing 16$ mm)
115-62578 ($\varnothing 20$ mm)

Boring bar sleeve $\varnothing 32$ mm

165-63223 ($\varnothing 8$ mm)
165-63224 ($\varnothing 10$ mm)
165-63225 ($\varnothing 12$ mm)
165-63226 ($\varnothing 16$ mm)
165-63227 ($\varnothing 20$ mm)
165-63228 ($\varnothing 25$ mm)

Boring bar sleeve $\varnothing 40$ mm

165-64075 ($\varnothing 8$ mm)
165-64076 ($\varnothing 10$ mm)
165-64077 ($\varnothing 12$ mm)
165-64078 ($\varnothing 16$ mm)
165-64079 ($\varnothing 20$ mm)
165-64080 ($\varnothing 25$ mm)
165-64081 ($\varnothing 32$ mm)

Toolholder for insert drill

- E1-30x08WN ($\varnothing 8$ mm)
- E1-30x10WN ($\varnothing 10$ mm)
- E1-30x12WN ($\varnothing 12$ mm)
- E1-30x16 ($\varnothing 16$ mm)
- E1-30x20 ($\varnothing 20$ mm)
- E1-30x25 ($\varnothing 25$ mm)
- E1-30x32 ($\varnothing 32$ mm)
- E1-30x40 ($\varnothing 40$ mm)



Toolholder for boring bar

- E2-30x6 ($\varnothing 6$ mm)
- E2-30x8 ($\varnothing 8$ mm)
- E2-30x10 ($\varnothing 10$ mm)
- E2-30x12 ($\varnothing 12$ mm)
- E2-30x16 ($\varnothing 16$ mm)
- E2-30x20 ($\varnothing 20$ mm)
- E2-30x25 ($\varnothing 25$ mm)
- E2-30x32 ($\varnothing 32$ mm)
- E2-30x40 ($\varnothing 40$ mm)



Double holder for boring bar

- E7-30x25 ($\varnothing 25$ mm)

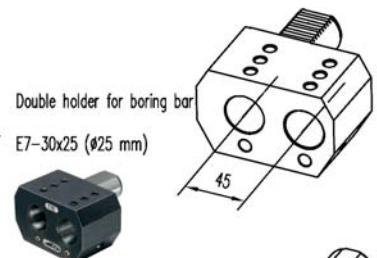

Toolholder with cylindrical shank

- 137-00041 ($\varnothing 40$ mm/HSK50A+C)



Collet chuck

- E4-30x16 (ER16)
- E4-30x20 (ER20)
- E4-30x25 (ER25)
- E4-30x32 (ER32)
- E4-30x40 (ER40)



Drilling chuck

- KS2-30-13 ($\varnothing 1$ - $\varnothing 13$ mm)
- KS2-30-16 ($\varnothing 3$ - $\varnothing 16$ mm)



DMG MORI (VDI30)

CTX 310/410 V4/V6 - CTX 320 V4/V6
 CTX 420 V4/V6 (option) - CTX Alpha 300 V4
 CTX Alpha 500 V 4/V6
 CTX Beta 500/800/1250 V4/V6 (option)
 TWIN 42/65/102
 SPRINT 65/50

RADIAL TURRET

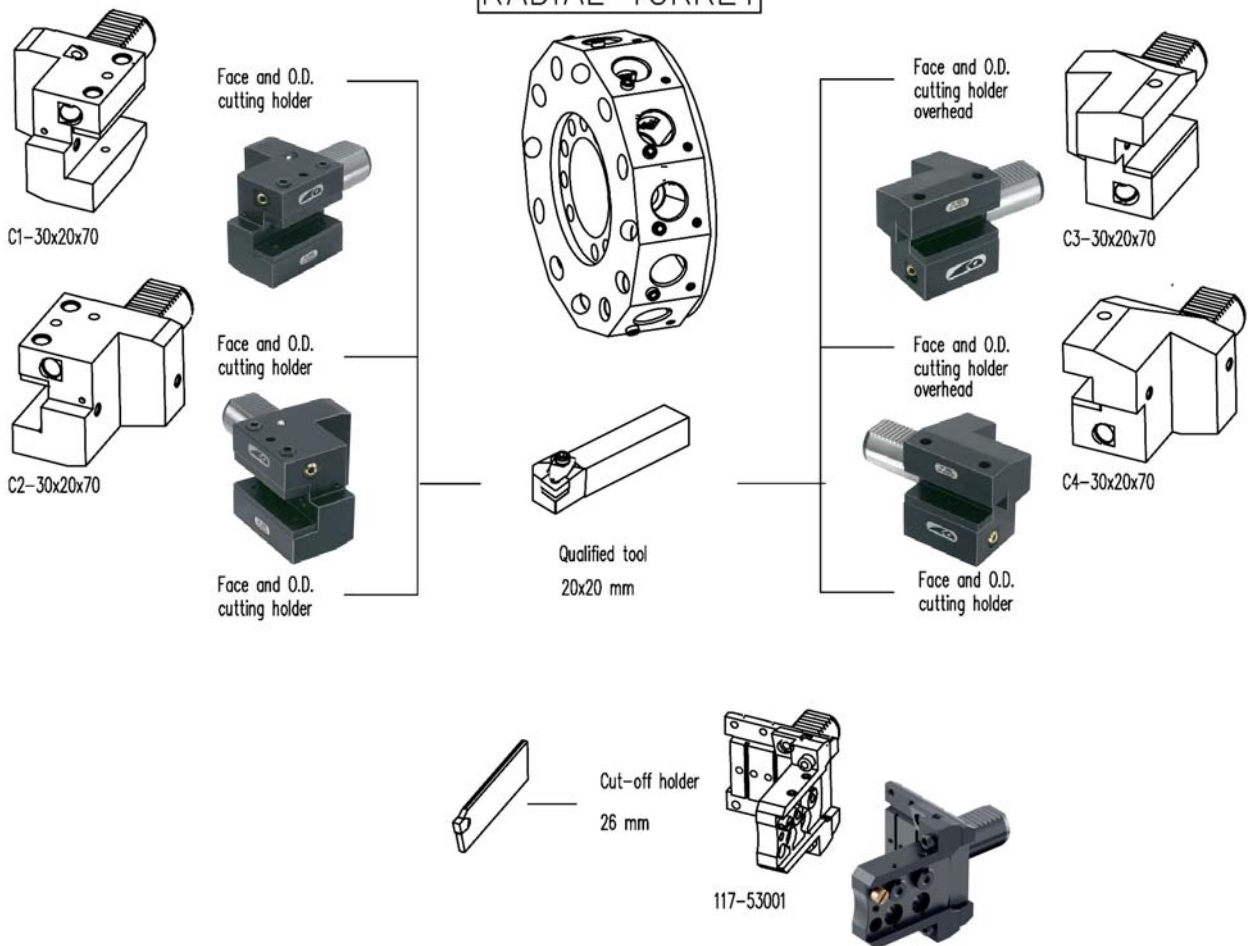

DMG MORI
(VDI30)

CTX310/410 V4/V6 - CTX 320 V4/V6
 CTX420 V4/V6 (option) - CTX Alpha 300 V4
 CTX Alpha 500 V4/V6
 CTX Beta 500/800/1250 V4/V6 (option)
 TWIN 42/65/102
 SPRINT 65/50

RADIAL TURRET

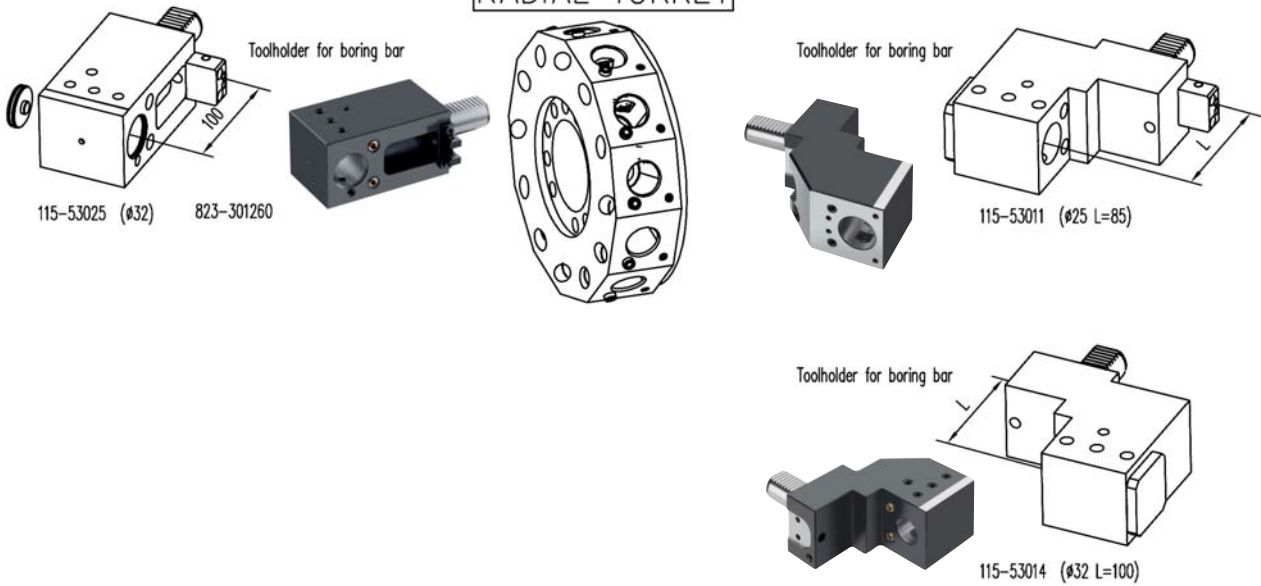

ACCESSORIES

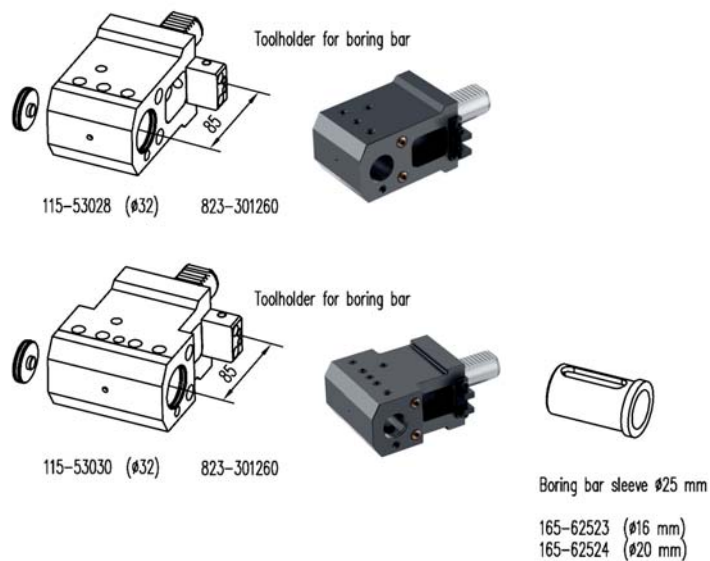

DMG MORI

(VDI40)

CTX410 V3 (option)
 CTX510 V3/V4
 CTX420 V3 (option)
 CTX520 V3/V4
 CTX Beta 500/800/1250 V3/V4
 CTX Gamma 1250/2000 V3/V4 (option)

AXIAL TURRET

Face and O.D. cutting holder
 B1-40X25X44

Face and O.D. cutting holder overhead
 B3-40X25X44

Face and O.D. cutting holder
 B5-40X25X44

Face and O.D. cutting holder overhead
 B7-40X25X44

Cut-off holder
 26 mm/32 mm
 AR4026
 AR4032

Bar puller
 KH1-40

VDI damped, adjustable, stop bar
 MW-4042-AM

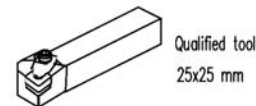
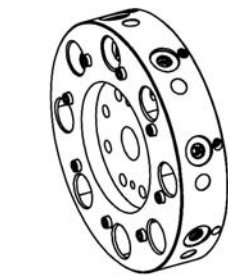

ACCESSORIES



Boring bar sleeve $\varnothing 25$ mm

- 115-62579 ($\varnothing 8$ mm)
- 115-62580 ($\varnothing 10$ mm)
- 115-62581 ($\varnothing 12$ mm)
- 115-62582 ($\varnothing 16$ mm)
- 115-62583 ($\varnothing 20$ mm)

Boring bar sleeve $\varnothing 32$ mm

- 165-63223 ($\varnothing 8$ mm)
- 165-63224 ($\varnothing 10$ mm)
- 165-63225 ($\varnothing 12$ mm)
- 165-63226 ($\varnothing 16$ mm)
- 165-63227 ($\varnothing 20$ mm)
- 165-63228 ($\varnothing 25$ mm)

Boring bar sleeve $\varnothing 40$ mm

- 165-64082 ($\varnothing 8$ mm)
- 165-64083 ($\varnothing 10$ mm)
- 165-64084 ($\varnothing 12$ mm)
- 165-64085 ($\varnothing 16$ mm)
- 165-64086 ($\varnothing 20$ mm)
- 165-64087 ($\varnothing 25$ mm)
- 165-64088 ($\varnothing 32$ mm)

Toolholder for insert drill

- E1-40x06WN ($\varnothing 6$ mm)
- E1-40x08WN ($\varnothing 8$ mm)
- E1-40x10WN ($\varnothing 10$ mm)
- E1-40x12WN ($\varnothing 12$ mm)
- E1-40x16 ($\varnothing 16$ mm)
- E1-40x20 ($\varnothing 20$ mm)
- E1-40x25 ($\varnothing 25$ mm)
- E1-40x32 ($\varnothing 32$ mm)
- E1-40x40 ($\varnothing 40$ mm)
- E1-40x50 ($\varnothing 50$ mm)

Toolholder for boring bar

- E2-40x6 ($\varnothing 6$ mm)
- E2-40x8 ($\varnothing 8$ mm)
- E2-40x10 ($\varnothing 10$ mm)
- E2-40x12 ($\varnothing 12$ mm)
- E2-40x16 ($\varnothing 16$ mm)
- E2-40x20 ($\varnothing 20$ mm)
- E2-40x25 ($\varnothing 25$ mm)
- E2-40x32 ($\varnothing 32$ mm)
- E2-40x40 ($\varnothing 40$ mm)
- E2-40x50 ($\varnothing 50$ mm)

Double holder for boring bar

E7-40x32 ($\varnothing 32$ mm)

Collet chuck

- E4-40x20 (ER20)
- E4-40x25 (ER25)
- E4-40x32 (ER32)
- E4-40x40 (ER40)

Drilling chuck

- KS2-40-13 ($\varnothing 1$ - $\varnothing 13$ mm)
- KS2-40-16 ($\varnothing 3$ - $\varnothing 16$ mm)

DMG MORI
(VDI40)

CTX410 V4/V6 (option) - CTX420 V4/V6
CTXBeta 500/800/1250 V6
TWIN42/65/102 RG2 - GMX250/300/400/500
SPRINT65 (option)

RADIAL TURRET

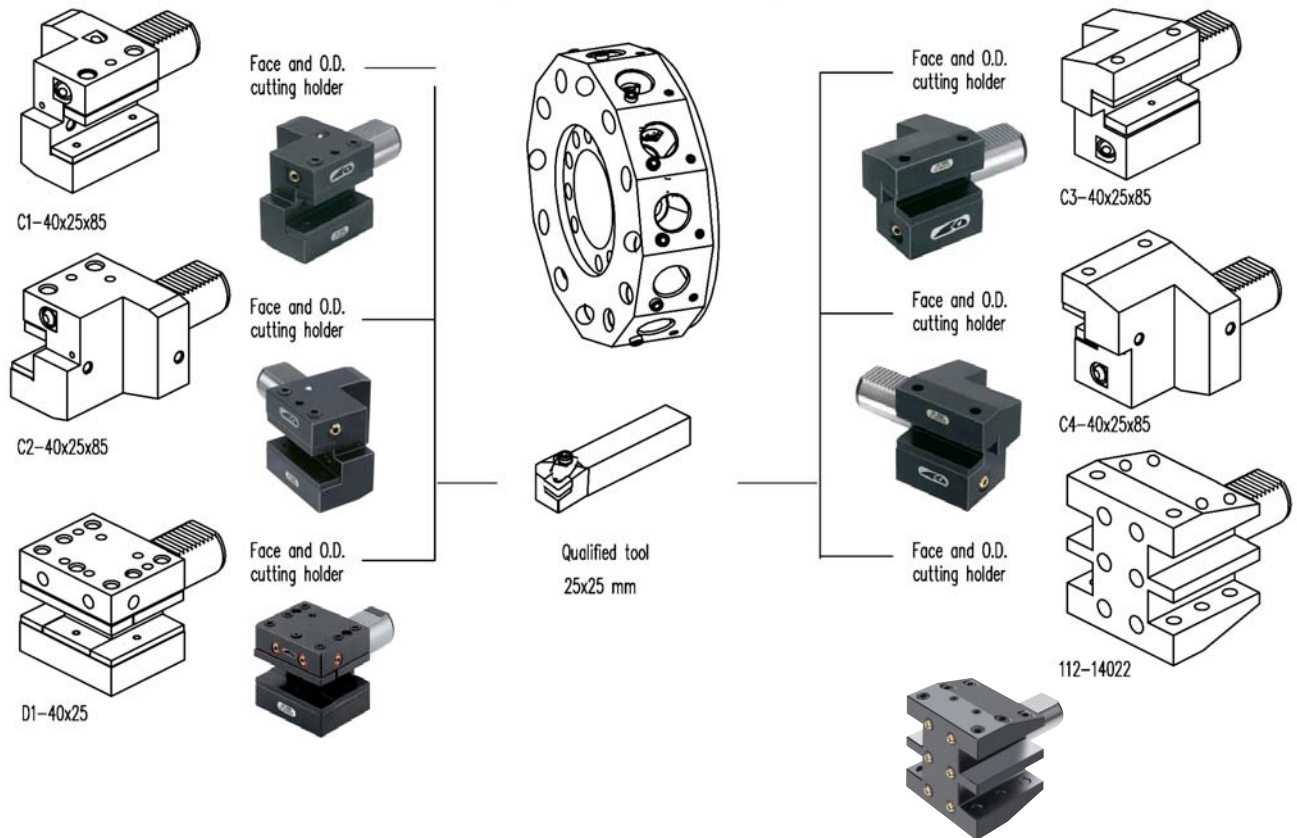

DMG MORI

(VDI40)

CTX410 V4/V6 (option) - CTX420 V4/V6
 CTXBeta 500/800/1250 V4/V6
 TWIN42/65/102 RG2 - GMX250/300/400/500
 SPRINT65 (option)

RADIAL TURRET

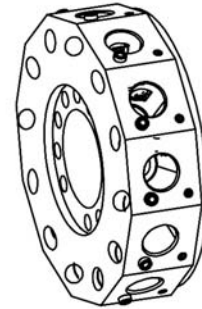
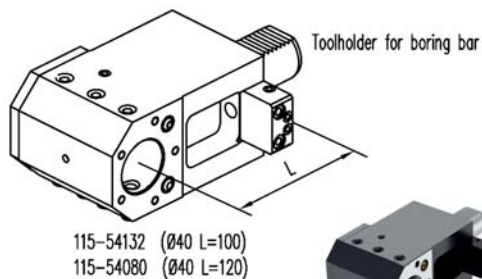
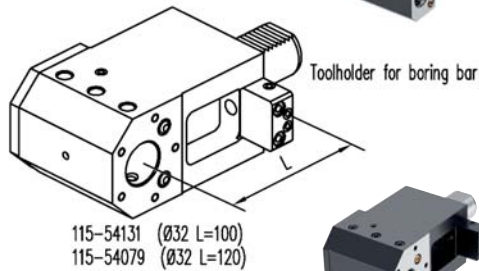
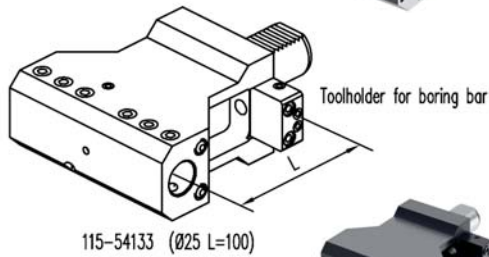
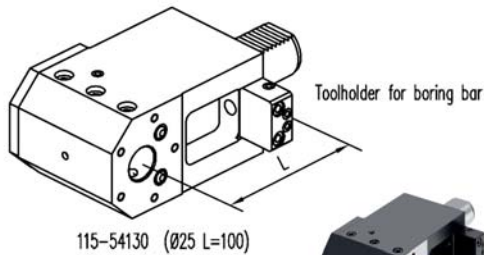

ACCESSORIES



- Boring bar sleeve (Ø25)
- 115-62579 (Ø8)
 - 115-62580 (Ø10)
 - 115-62581 (Ø12)
 - 115-62582 (Ø16)
 - 115-62583 (Ø20)



- Boring bar sleeve (Ø32)
- 165-63223 (Ø8)
 - 165-63224 (Ø10)
 - 165-63225 (Ø12)
 - 165-63226 (Ø16)
 - 165-63227 (Ø20)
 - 165-63228 (Ø25)



- Boring bar sleeve (Ø40)
- 165-64082 (Ø8)
 - 165-64083 (Ø10)
 - 165-64084 (Ø12)
 - 165-64085 (Ø16)
 - 165-64086 (Ø20)
 - 165-64087 (Ø25)
 - 165-64088 (Ø32)

Double toolholder for boring bar

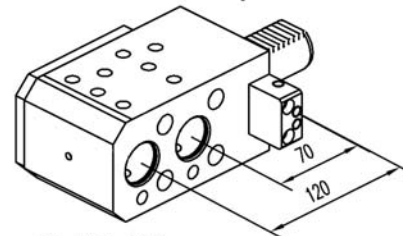

DMG MORI
(VDI50)

CTX620 V3/V4/V1
CTX Gamma 1250/2000 V3/V4
CTV400
CTX Beta 2000

AXIAL TURRET

Face and O.D. cutting holder
B1-50x32x55

Face and O.D. cutting holder overhead
B3-50x32x55

Face and O.D. cutting holder
B5-50x32x55

Face and O.D. cutting holder overhead
B7-50x32x55

Cut-off holder
26 mm/32 mm
AR5026
AR5032

Bar puller
KH1-50

VDI damped, adjustable, stop bar
MW-5042-AM

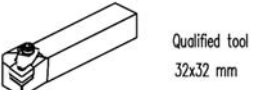
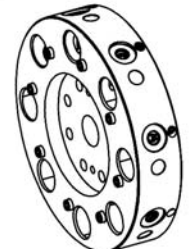

ACCESSORIES

- Boring bar sleeve #25 mm**
- 115-62584 (Ø8 mm)
 - 115-62585 (Ø10 mm)
 - 115-62586 (Ø12 mm)
 - 115-62587 (Ø16 mm)
 - 115-62588 (Ø20 mm)

- Boring bar sleeve #32 mm**
- 165-63229 (Ø8 mm)
 - 165-63230 (Ø10 mm)
 - 165-63231 (Ø12 mm)
 - 165-63232 (Ø16 mm)
 - 165-63233 (Ø20 mm)
 - 165-63234 (Ø25 mm)

- Boring bar sleeve #40 mm**
- 165-64082 (Ø8 mm)
 - 165-64083 (Ø10 mm)
 - 165-64084 (Ø12 mm)
 - 165-64085 (Ø16 mm)
 - 165-64086 (Ø20 mm)
 - 165-64087 (Ø25 mm)
 - 165-64088 (Ø32 mm)

Toolholder for insert drill

- E1-50x16 (Ø16 mm)
- E1-50x20 (Ø20 mm)
- E1-50x25 (Ø25 mm)
- E1-50x32 (Ø32 mm)
- E1-50x40 (Ø40 mm)
- E1-50x50 (Ø50 mm)

Toolholder for boring bar

- E2-50x12 (Ø12 mm)
- E2-50x16 (Ø16 mm)
- E2-50x20 (Ø20 mm)
- E2-50x25 (Ø25 mm)
- E2-50x32 (Ø32 mm)
- E2-50x40 (Ø40 mm)
- E2-50x50 (Ø50 mm)

Double holder for boring bar

- E7-50x32 (Ø32 mm L=50 mm)
- E7-50x50 (Ø50 mm L=68 mm)

Collet chuck

- E4-50x25 (ER25)
- E4-50x32 (ER32)
- E4-50x40 (ER40)

Drilling chuck

- KS2-50-13 (Ø1-Ø13 mm)
- KS2-50-16 (Ø3-Ø16 mm)

DMG MORI (HSK63T) GMX400 - GMX300 - GMX250

ATC Turret (HSK63T)

ICTM STANDARD

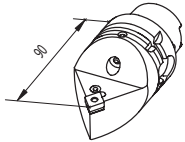

H63APCMNR12-90

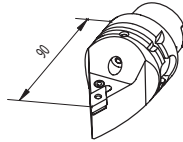

H63APDNNR15-90

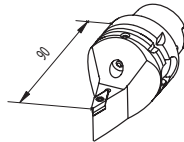

H63ASVVCN16-90

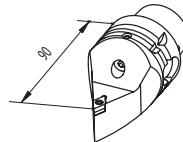

H63ASDNCN11-90

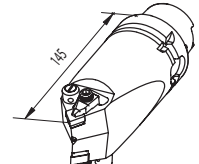

H63ADCM12DDM15-L145

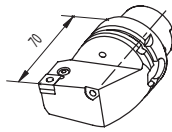

H63APCLNL/R12

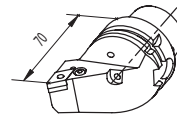

H63APDJNL/R15

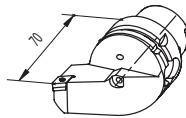

H63ASDJCL/R11

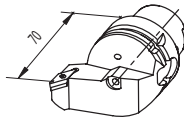

H63ASVJBL/R16

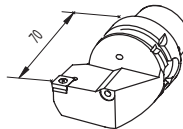

H63ASCLCL/R12

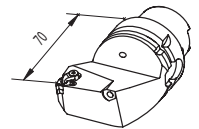

H63ATHEL/R16

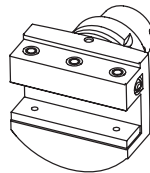

141-11408 32/25

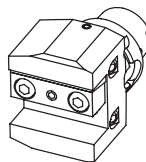

141-11406 25x25 mm

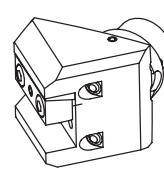

141-11405 25x25 mm

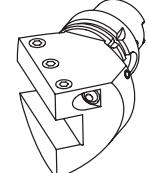

141-11407 (left) 25x25 mm
141-21401 (right)

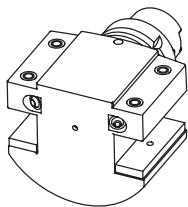

142-11405 32/25
142-11406 32/25

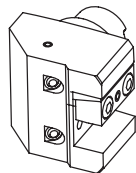

142-11402 25x25 mm

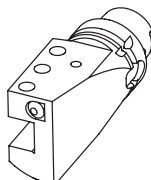

142-21401 (left) 25x25 mm
142-11403 (right)

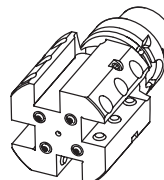

142-21404 20x20 mm (right)
142-21403 20x20 mm (left)

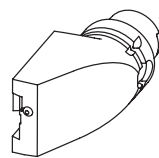

147-51405 (26mm, left)
147-51406 (26mm, right)
147-51407 (32mm, left)
147-51408 (32mm, right)

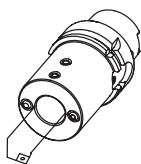

145-21404 (Ø12)
145-21406 (Ø16)
145-21408 (Ø20)
145-21409 (Ø25)
145-21410 (Ø32)
145-21411 (Ø40)

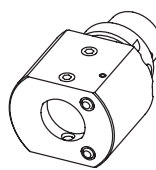

145-21412 Ø40 mm



165-64124 (Ø10 mm)
165-64125 (Ø12 mm)
165-64126 (Ø16 mm)
165-64127 (Ø20 mm)



165-64128 (Ø25 mm)
165-64129 (Ø32 mm)

DMG MORI
(BMT40)

CTX310ECO-BMT / NZ1500 / NZ2000 / NTX1000-2000

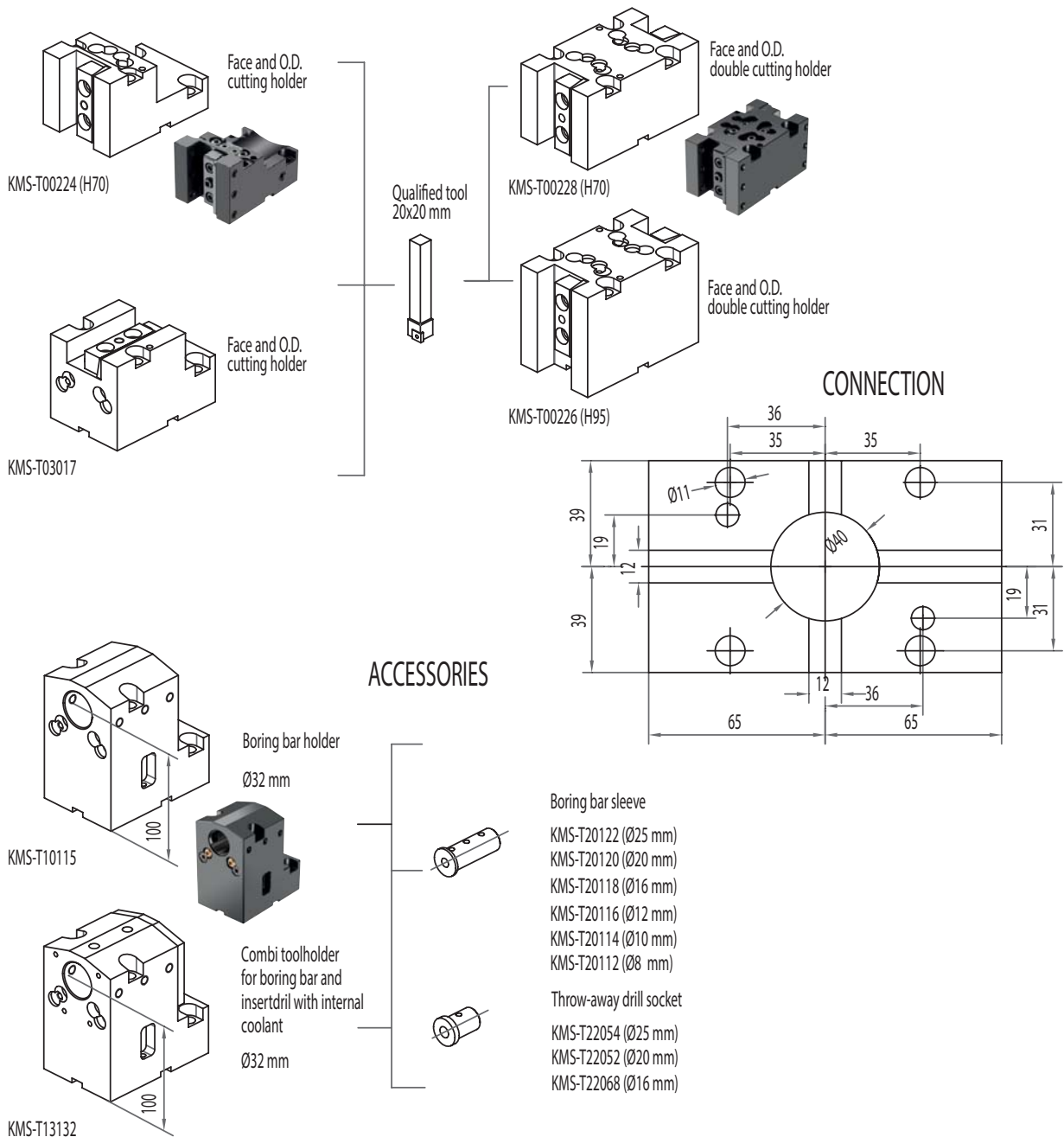

DMG MORI (BMT60)

NLX1500 - NLX2000 - NLX2500 - NLX3000
 NL2000 (S)MC - 2500 (S)MC - NL3000MC (12 STATIONS)
 NT3250 - NT4200 - NT4250 - NT4300 - NT5400
 NZL2500

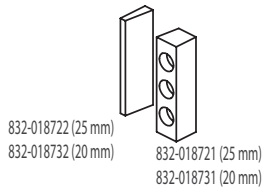

CONNECTION

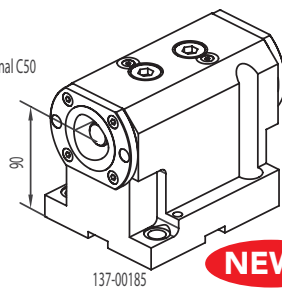
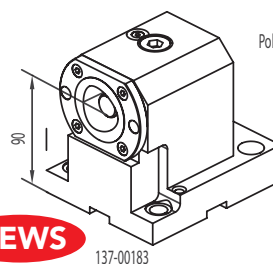
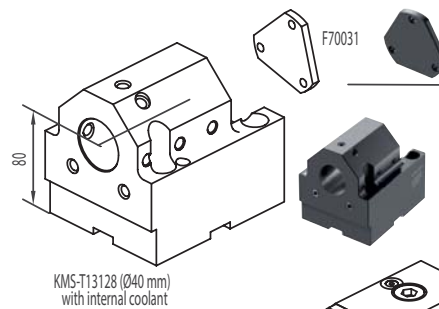
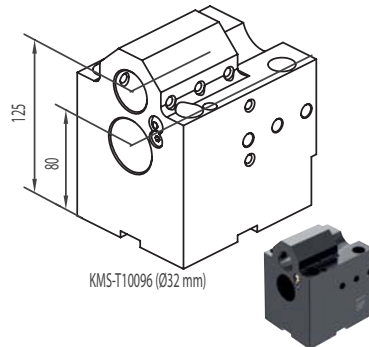
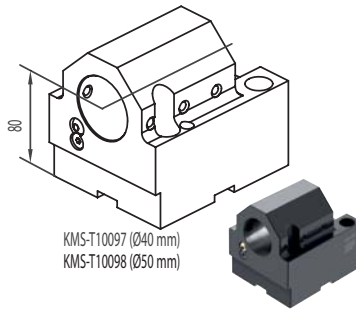
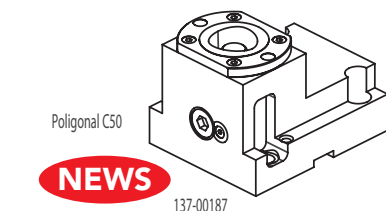
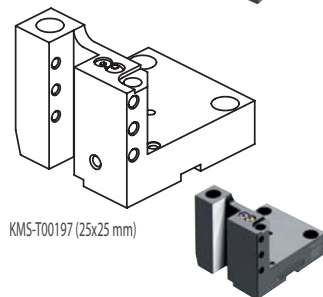
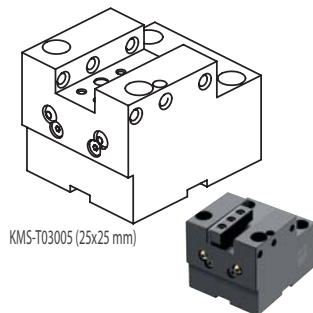
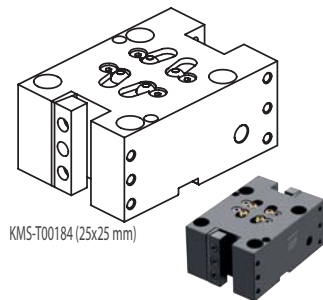
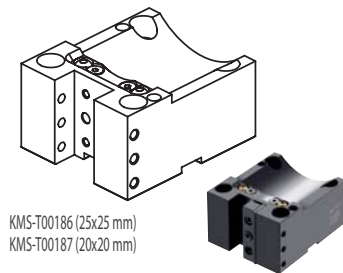
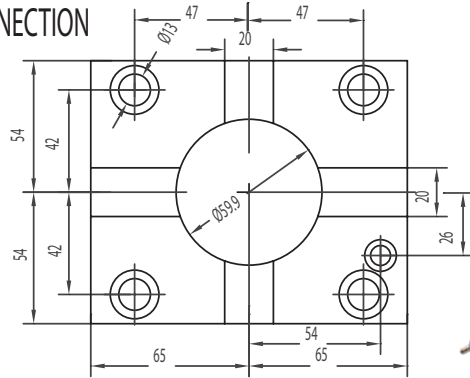

ACCESSORIES

- KMS-T20098-A (Ø32 mm)
- KMS-T20096-A (Ø25 mm)
- KMS-T20094-A (Ø20 mm)
- KMS-T20092-A (Ø16 mm)
- KMS-T20090-A (Ø12 mm)
- KMS-T20088-A (Ø10 mm)
- KMS-T20086-A (Ø8 mm)

- KMS-T20196-A (Ø20 mm)
- KMS-T20194-A (Ø16 mm)
- KMS-T20110-A (Ø12 mm)
- KMS-T20108-A (Ø10 mm)
- KMS-T20106-A (Ø8 mm)

- KMS-T22042-A (MT3)
- KMS-T22044-A (MT4)
- KMS-T22046-A (MT2)
- KMS-T22066-A (MT1)

- KMS-T20122-A (Ø25 mm)
- KMS-T20120-A (Ø20 mm)
- KMS-T20118-A (Ø16 mm)
- KMS-T20116-A (Ø12 mm)
- KMS-T20114-A (Ø10 mm)
- KMS-T20112-A (Ø8 mm)

- KMS-T20100-A (Ø32 mm)
- KMS-T20102-A (Ø25 mm)
- KMS-T20104-A (Ø20 mm)
- KMS-T20190-A (Ø16 mm)

DMG MORI
CMZ

SL203MC - SL253MC - ZL200MC
ZL250SMC - SL204SMC - SL300MC
TL20 - TL25 - TC30 - TC35

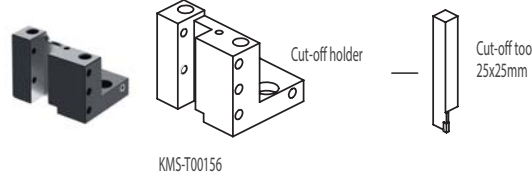
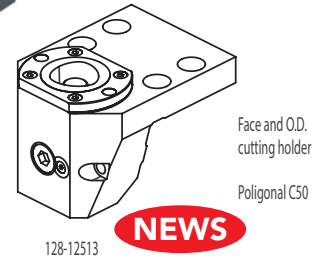
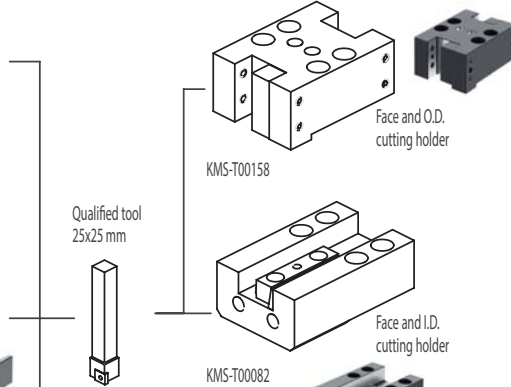
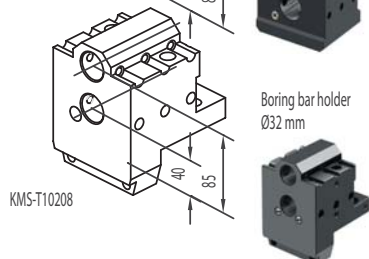
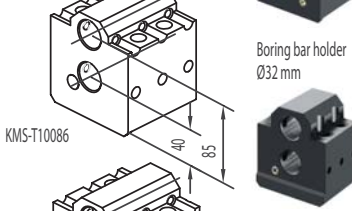
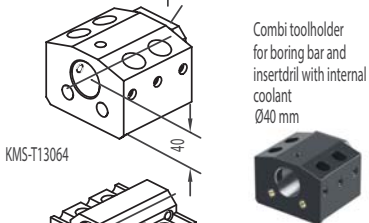
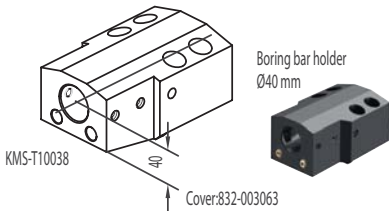
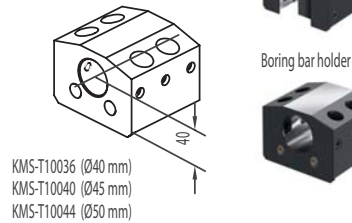
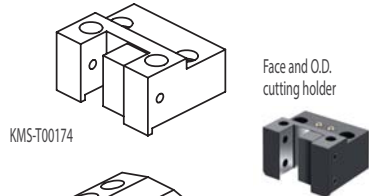
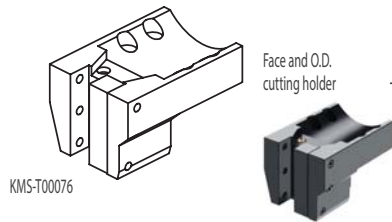
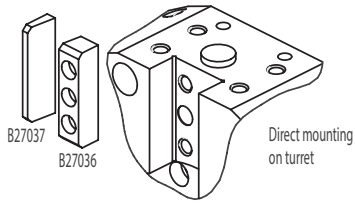

ACCESSORIES

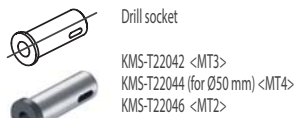

CONNECTION

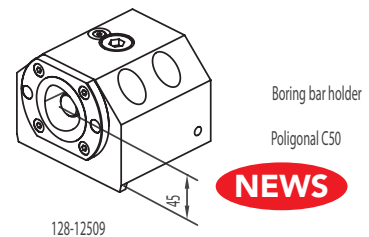
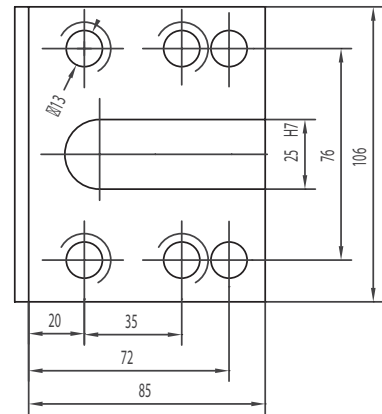

DMG MORI CTX Gamma 1250TC / 2000TC

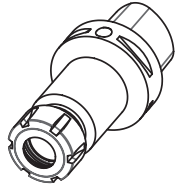

C63H60ER16 C63H100ER16
 C63H60ER20 C63H100ER20
 C63H60ER25 C63H100ER25
 C63H60ER32 C63H100ER32
 C63H70ER40 C63H130ER40



C63H55WE06 C63H65WE16
 C63H55WE08 C63H65WE20
 C63H60WE10 C63H80WE25
 C63H60WE12 C63H90WE32
 C63H60WE14

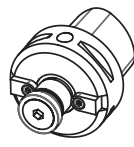

C63H40D16 C63H100D27
 C63H63D16 C63H25D32
 C63H25D22 C63H100D32
 C63H100D22 C63H40D40
 C63H25D27 C63H100D40

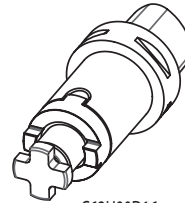

C63H90D16
 C63H90D22
 C63H90D27
 C63H90D32
 C63H90D40

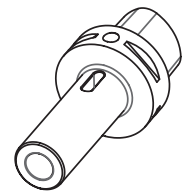

C63H110CM2P
 C63H130CM3P
 C63H150CM4P

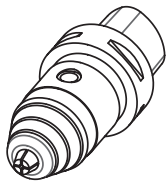

C63H112R1-13
 C63H112R3-16



C63GR1
 C63GR2

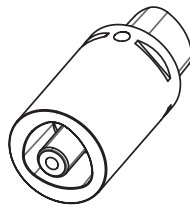

C63H100C63
 C63H140C63

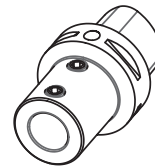

C63H60D08PNT C63H70D20PNT
 C63H60D10PNT C63H72D25PNT
 C63H60D12PNT C63H75D32PNT
 C63H70D16PNT C63H75D40PNT

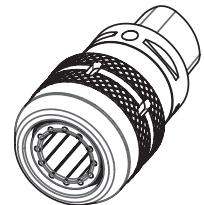

C63H80C20
 C63H100C32

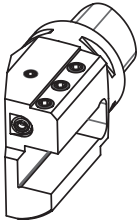

C63-AD2020R/L
 C63-AD2525R/L
 C63-AD3232R/L

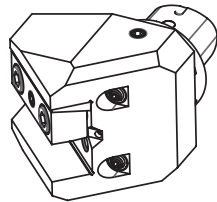

C63-ARD2525-45

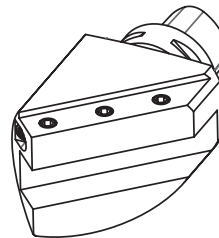

C63AR20R/L
 C63AR25R/L

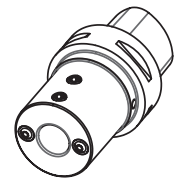

C63H80D16E2
 C63H80D20E2
 C63H88D25E2
 C63H95D32E2
 C63H105D40E2

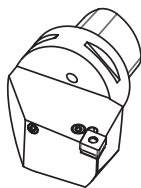

C63-PCLNR/L12
 C63-PCLNR/R16



C63-PDJNR/L15



C63-25PCLNR/L12
 C63-32PCLNR/L12



C63-SCLCR/L09
 C63-SCLCR/R12



C63-SDJCR/L11

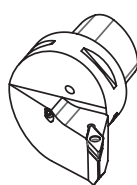

C63-SVHBR/L16
 C63-SVHCR/L16

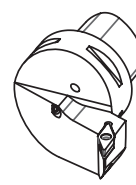

C63-SVJBR/L16
 C63-SVJCR/L16

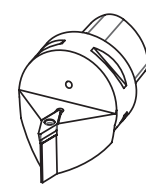

C63-SVVCN16-190

DMG MORI SL150 - SL153 - ZL150 - CL150 - SL154

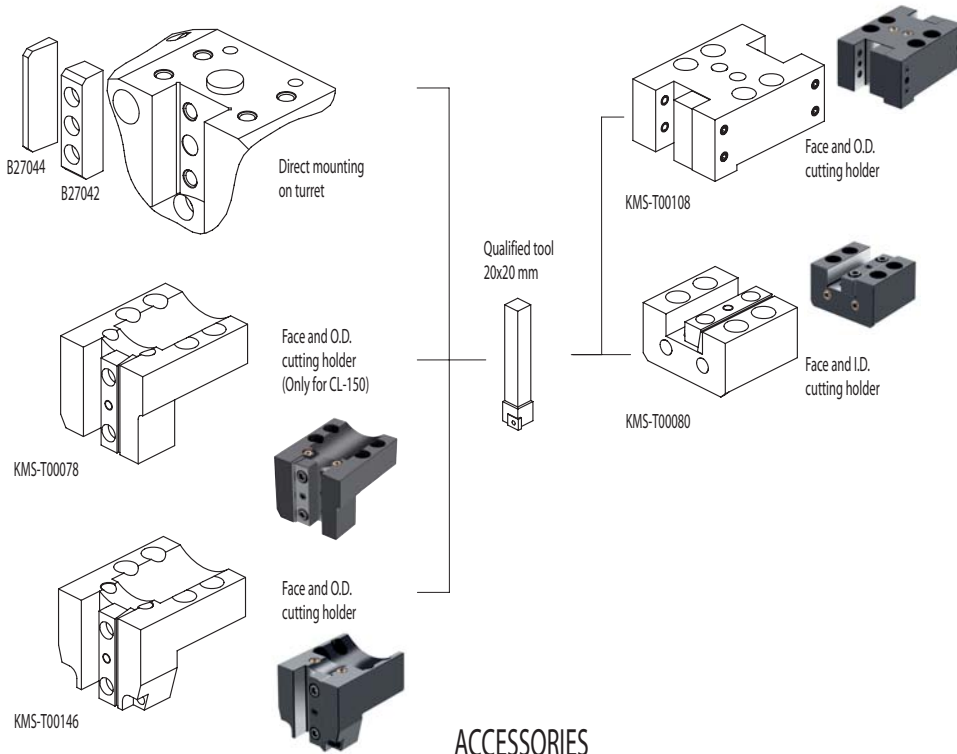

ACCESSORIES

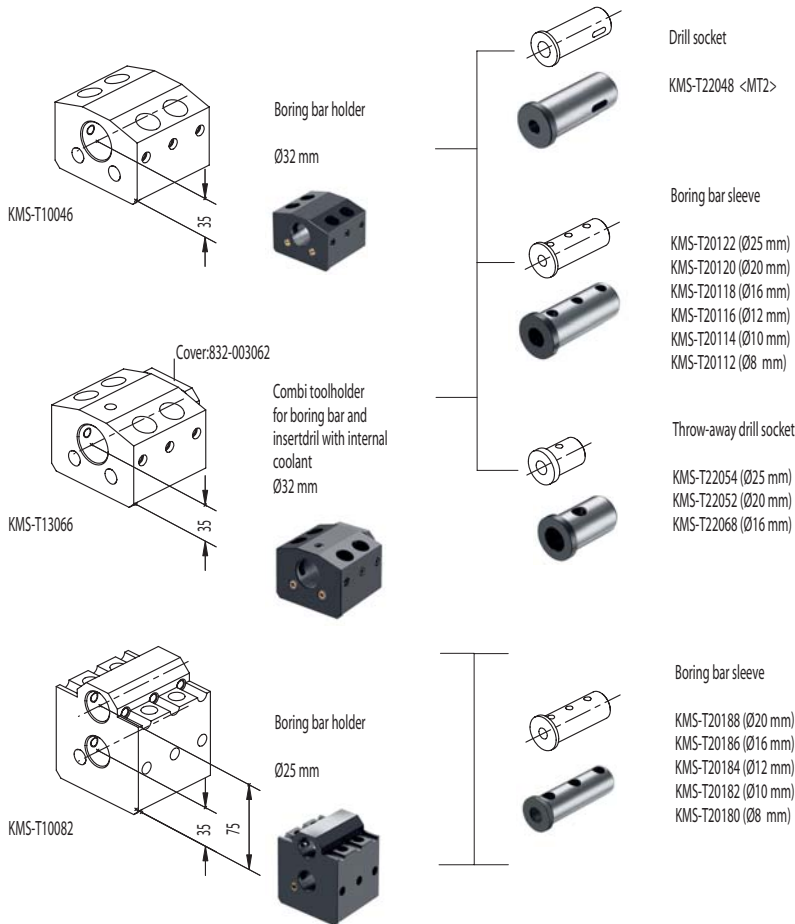

CONNECTION

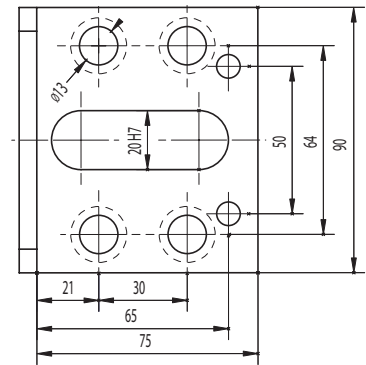

DMG MORI CMZ

SL153MC - ZL150MC - SL154MC TL15

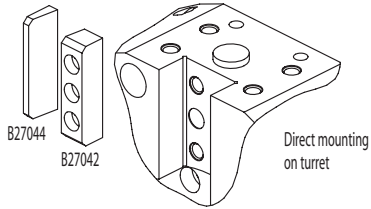

B27044
B27042

Qualified tool
20x20 mm

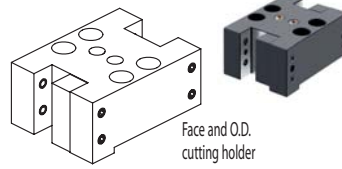

KMS-T00108

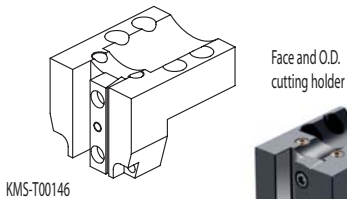

KMS-T00146

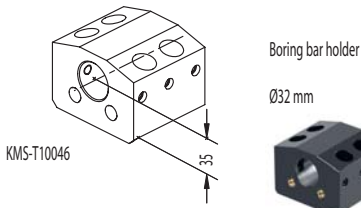

KMS-T10046

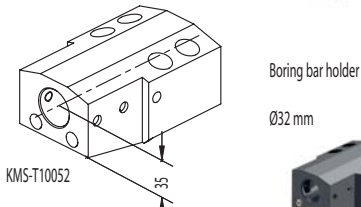

KMS-T10052

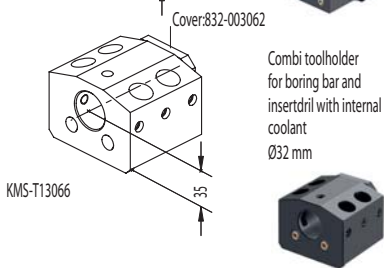

KMS-T13066

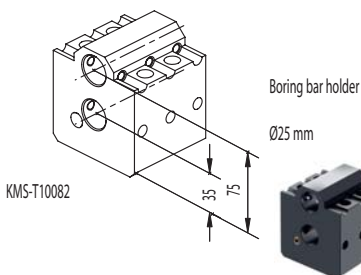

KMS-T10082

ACCESSORIES

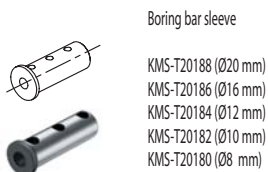
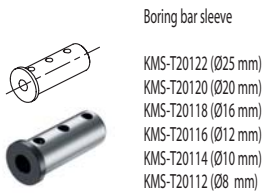

CONNECTION

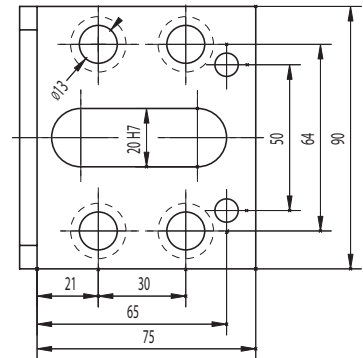

DMG MORI

**SL200 - SL203 - SL250 - SL253 - ZL200 - ZL250
(CL200) - SL204 - DURATURN 2030
DURATURN 2050 - DURATURN 2550**

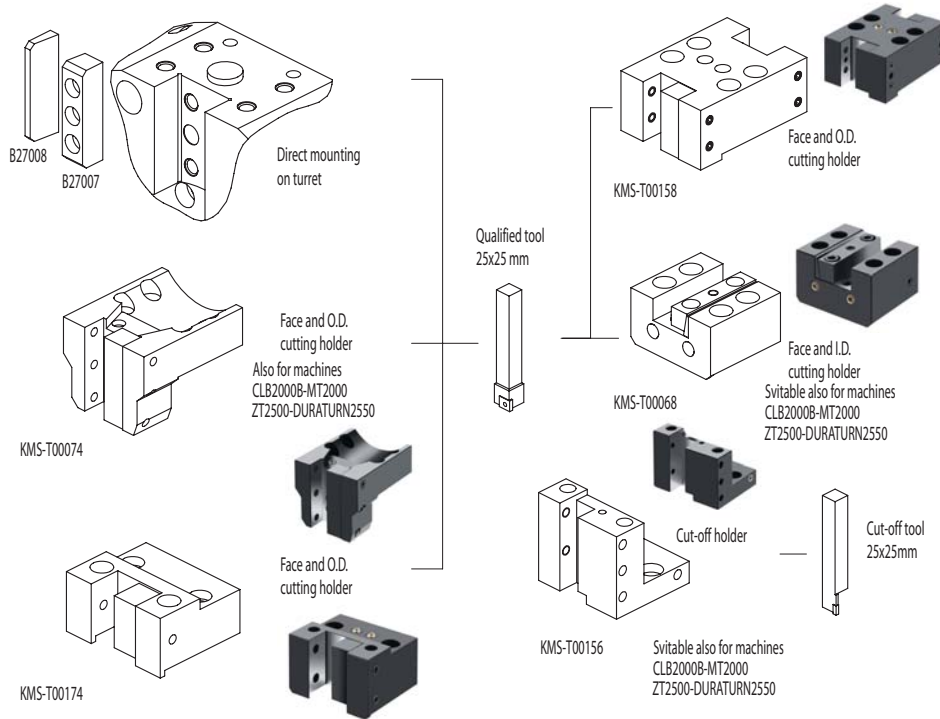

ACCESSORIES

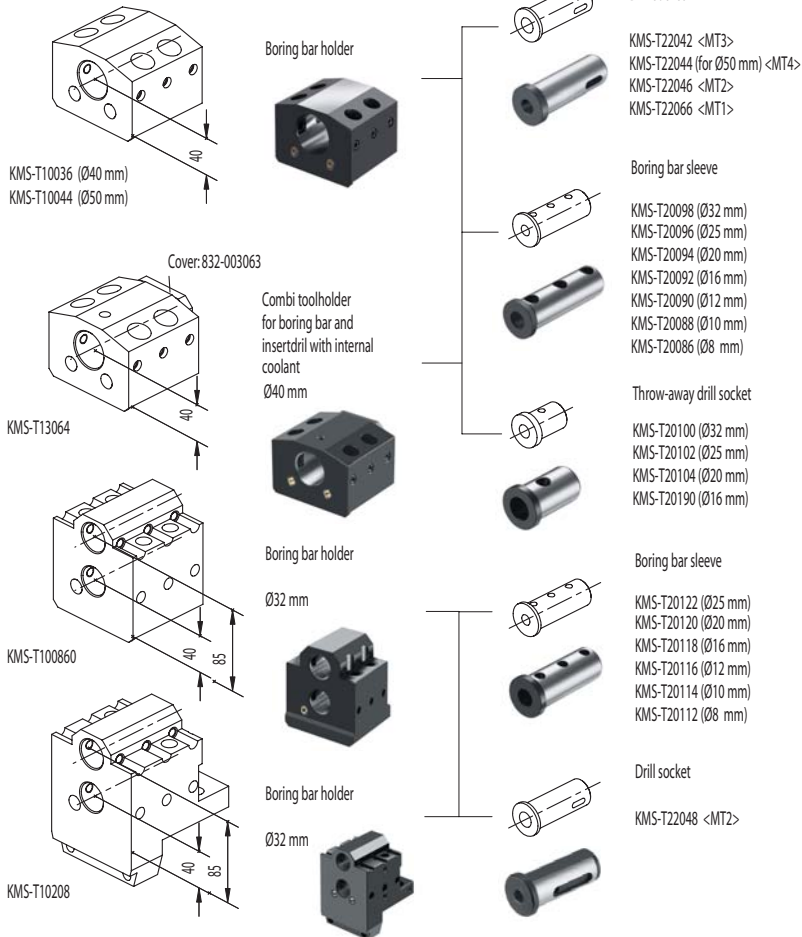

CONNECTION

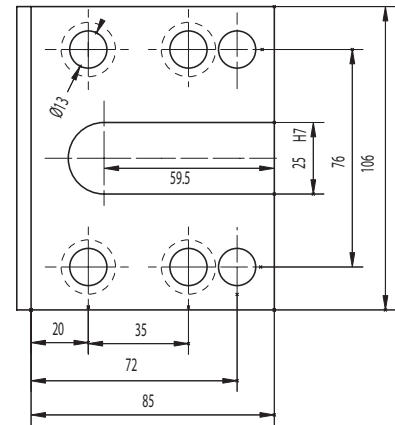

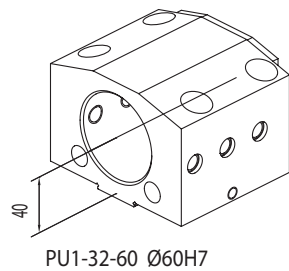
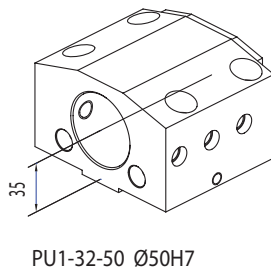
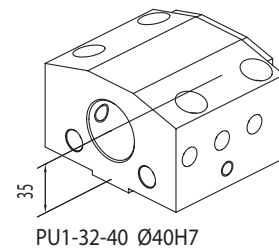
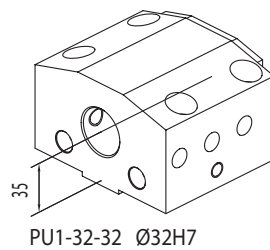
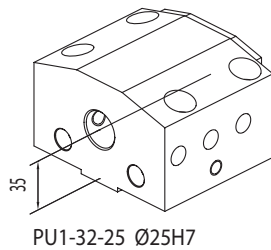
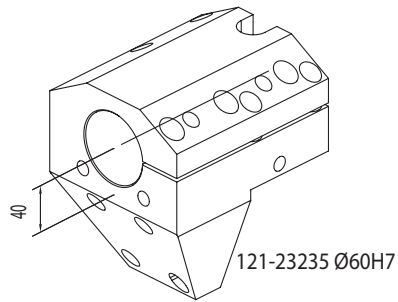
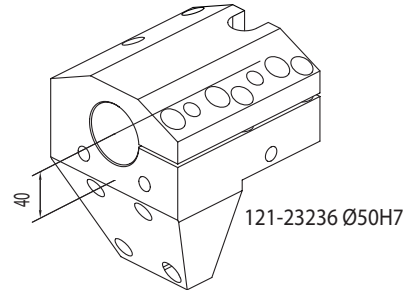
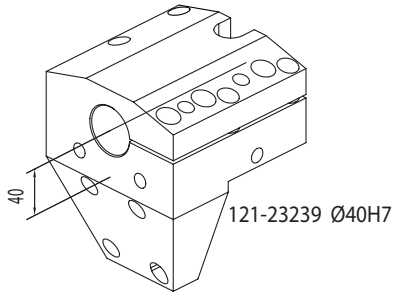
DMG MORI CXT620

DMG MORI CTX510

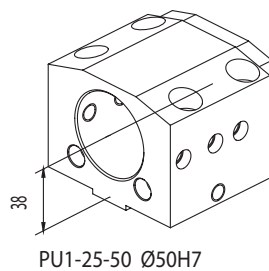
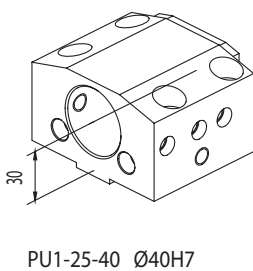
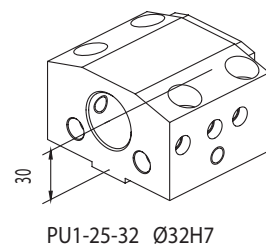
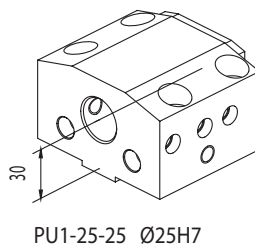
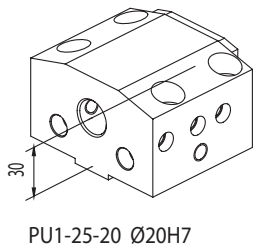
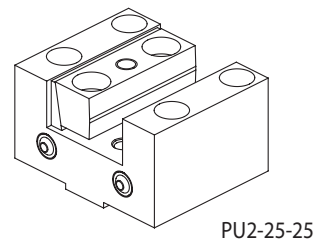
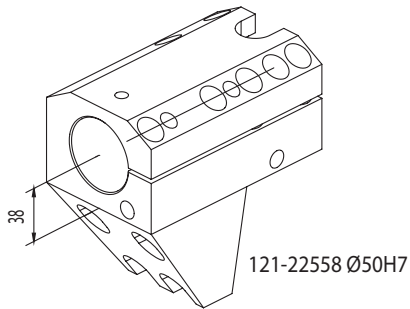
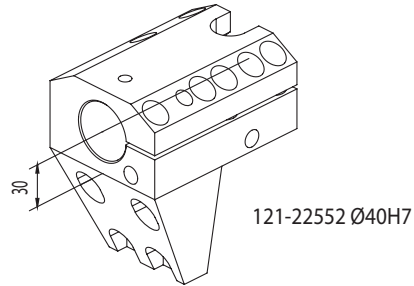



HEAD OFFICE
KINTEK S.R.L. - MAPPANO - TORINO - ITALY



NEW PRODUCTION PLANT
A.M.T S.R.L. - CASELLE T.SE - TORINO - ITALY



MAIN PRODUCTION PLANT
KINTEK TOOLING KFT - BEKESCSABA - HUNGARY

KINTEK

VIA GORETTA 88/G - 10072 MAPPANO
FRAZIONE DI CASELLE (TO) - ITALIA
Tel. +39.011.9968065 - Fax +39.011.9965662
<http://www.kintek.it> - e-mail: info@kintek.it